

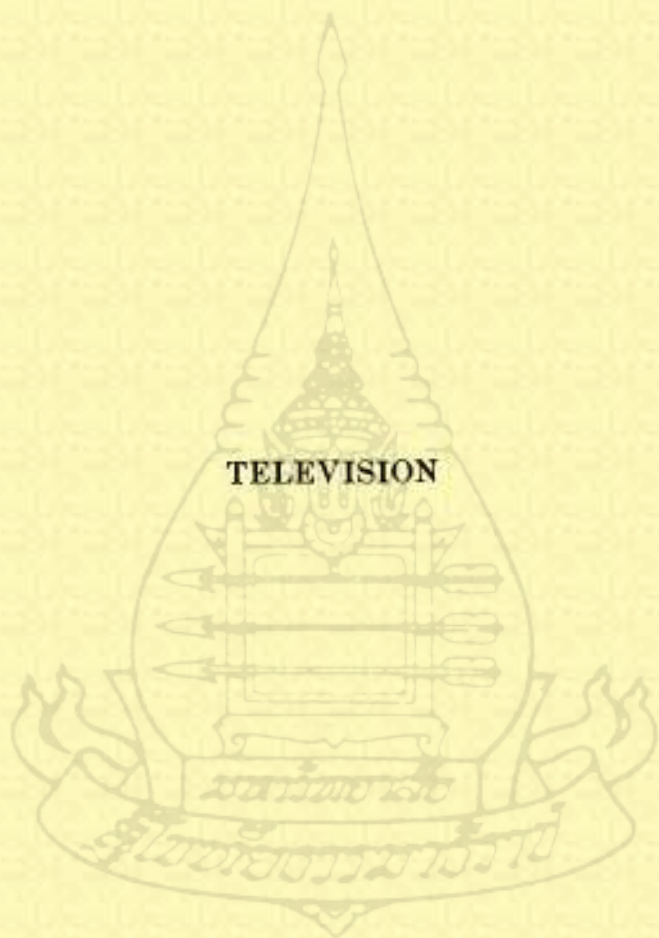

ໂຍຄາຕ ຫໍບເຕກຼີ
ອໍໂຍຄ ກຸງສໍ່ຈໍຍະ

ສູນໂຍທໍ່ສັງຄົມສາວົກປາຍ



TELEVISION

คณะกรรมการการกระจายเสียง
วิทยุกระจายเสียงและวิทยุโทรทัศน์

ส.ท.ช. (National Broadcasting Commission)

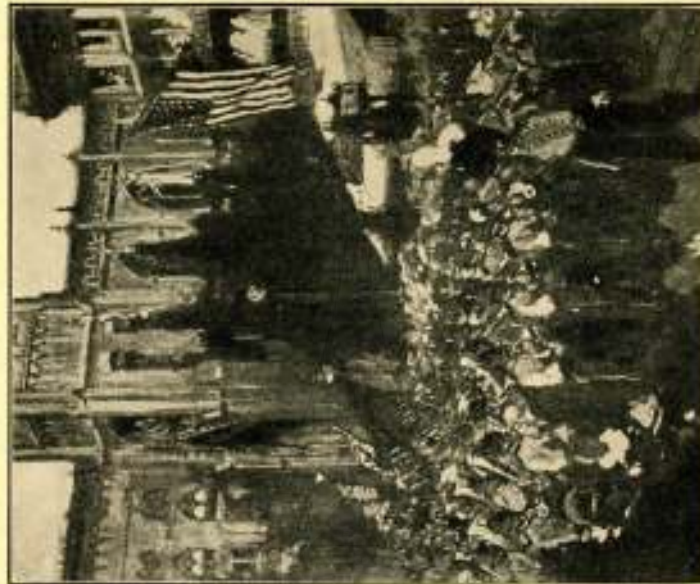
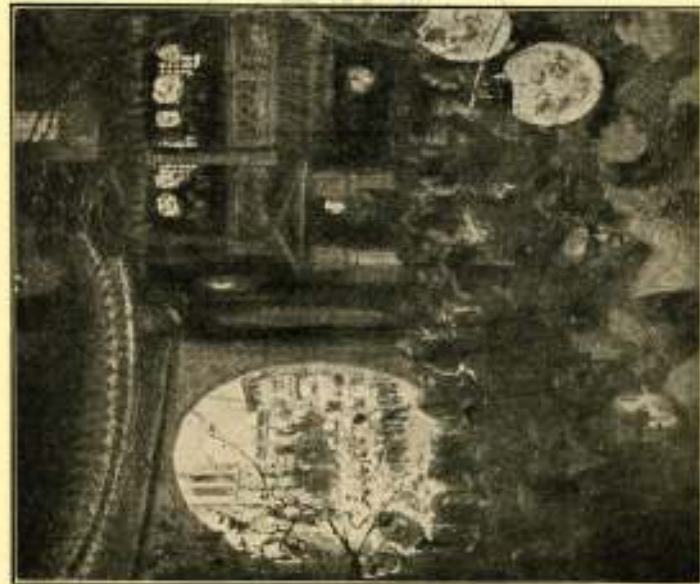

PHOTOGRAPHY.—An artist's conception of television broadcasting, published a third of a century ago. (From *Harper's Weekly*, December 29, 1900.)

TELEVISION

Its Methods and Uses

BY

EDGAR H. FELIX

*Broadcast Consultant; Member Institute of Radio Engineers;
Author, "Using Radio in Sales Promotion"*

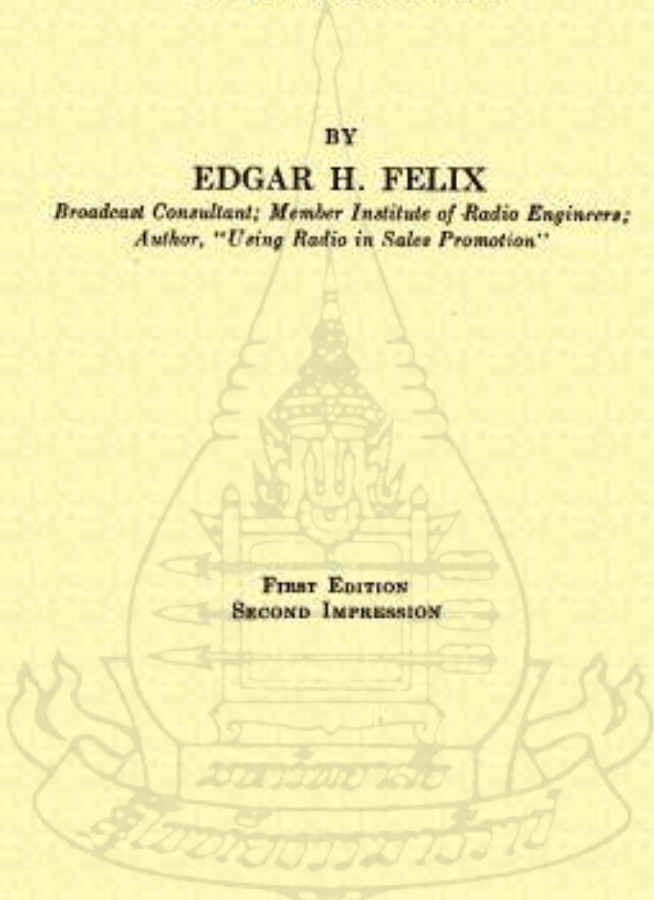

FIRST EDITION
SECOND IMPRESSION

McGRAW-HILL BOOK COMPANY, INC.

NEW YORK AND LONDON

1931

COPYRIGHT, 1931, BY THE
MCGRAW-HILL BOOK COMPANY, INC.

PRINTED IN THE UNITED STATES OF AMERICA

*All rights reserved. This book, or
parts thereof, may not be reproduced
in any form without permission of
the publishers.*



THE MAPLE PRESS COMPANY, YORK, PA.

PREFACE

The author of a book on television and in fact any book describing a technical science approaching commercialization has his choice of several points of view. He may disregard the present imperfect status of the science by simply not mentioning or totally disregarding existing shortcomings and problems; he may smother existing difficulties with rosy predictions and expression of enthusiasm; or he may treat them with the utmost frankness believing their conquest can come only through accurate understanding and comprehending research.

The present author has chosen the latter course, perhaps in reaction to the overabundance of optimistic treatments of television. He feels that a conservative attitude is particularly helpful at this time, because television has been treated to an excess of premature and unwarrantedly hopeful publicity. The author, of course, realizes that an exacting analysis of television as it exists today may be significantly altered by a development of tomorrow.

Even as he examines the proofs of this book, the publisher inquires whether an invention, just announced with considerable gusto and rewarded by tremendous publicity, has not indeed made all the conclusions therein hopelessly obsolete. But this announcement, like so many of its predecessors, is accompanied neither by technical proof nor by open demonstration. I have the satisfaction of knowing that readers of this book (if any) will be able to place an accurate valuation upon any announced invention

PREFACE

based entirely upon its potential contribution to the progress of television.

My purpose in writing this book has been to develop a clear understanding of how existing television systems work, the basic processes involved in any television system, the standards of performance essential to the rendition of a commercial service, the limitations of certain features of existing methods standing in the way of the attainment of commercial performance standards, and the nature of the developments still necessary to bring performance of public-service quality.

It is hoped that this volume will be of benefit to those desiring to establish television as a service, either by contributing to its technical advancement or by financing its progress, and to those planning to participate in its commercial development as manufacturers and broadcasters.

This volume has had the benefit of rather widespread collaboration and generous assistance from many of the leaders in the television field. I regret that my approach to the subject has not permitted me to give credit, but my purpose has been not so much to distinguish the contributions of individuals as to set forth the present and future status of the science. The manuscript has been reviewed by competent physicists and radio engineers directly engaged in television problems. Unfortunately, because of their connections, it is not practicable to give them credit, but I am glad to be able to mention my appreciation to Professor Arthur Dickson of the College of the City of New York, who has reviewed the manuscript.

RIDGEWOOD, N. J.,
June, 1931.

EDGAR H. FELIX.

CONTENTS

	PAGE
PREFACE	v
CHAPTER I	
THE PRESENT STATUS OF TELEVISION	1
Television Long Predicted—Nature of Recent Developments— When Will Television Arrive?—Fundamental Definitions	
CHAPTER II	
HEARING, VISION AND TELEVISION	7
Communication—Comparison of Sound and Visual Communica- tion—Visual Information Essential to Television—Reduction of Extent of Field of View—Minimum Repetition Rate	
CHAPTER III	
THE SIX PROCESSES OF TELEVISION	21
Scanning—Light Sensitive Element—Picture Signal—Light Producing Element—Receiving Scanning Disc—Commercial Standards for Television of Entertainment Value—A Typical Television System	
CHAPTER IV	
SCANNING THE FIELD OF VIEW	30
Purpose of Scanning—Lines and Picture Elements—Progressive Observation—Progressive Illumination—Effect of Large Scan- ning Disc Apertures—Distortion Introduced by Coarse Scanning —Progressive Illumination Installations—Limitations of Scan- ning Disc—Prismatic Discs—Rating the Quality of Scanning Systems—Scanning of Motion Pictures—Television Compared with Motion Pictures	
CHAPTER V	
THE LIGHT SENSITIVE ELEMENT	36
Photoelectric Phenomena—Selenium—Photoelectric Tube— Characteristics of Commercial Photoelectric Tubes—Coupling with Amplifier Systems	
CHAPTER VI	
TRANSMISSION OF TELEVISION SIGNALS	73
Limitations of Broadcast Receivers—Transmission Band Re-	

CONTENTS

	PAGE
quired by Television—Contribution of High Frequencies to Reproduction—Channel Requirements for Subjects of Various Dimensions and Detail—Selective Fading—Echo Images	
CHAPTER VII	
RECEPTION OF TELEVISION	92
Broadcast Receivers for Television—Special Requirements of Receivers for Television—Radio Frequency Amplifiers—Band Selector—Superheterodyne—Resistance Coupled Receivers	
CHAPTER VIII	
CONVERTING THE PICTURE SIGNAL TO LIGHT	102
Neon Glow Tube—Water Cooled Neon Tube—Concentrated Illumination Neon Tube—Color Television—Drum Scanner— Neon Grid Screen—Cathode Ray Tube—Kerr Principle— Polarized Light—Karolus Valve Projector	
CHAPTER IX	
FORMING THE IMAGE IN THE FIELD OF REPRODUCTION	120
Repetition Rate—Limitations of the Scanning Disc—Relation of Brilliance to Number of Picture Elements Required—Pro- jection—Reproduction of Color Television	
CHAPTER X	
SYNCHRONIZATION OF TELEVISION	137
Essentials to Faithful Television Reproduction—Effect of Inaccurate Synchronization—Degree of Accuracy Required— Manual Methods of Synchronizing—Power Line Synchronization —Effect of Voltage Changes and Load on Synchronous Motors— Systems Depending upon Synchronous Motors—Vacuum Tube Regulator—Short Wave Synchronizing—Independent Genera- tion of Control Frequency—Framing the Image	
CHAPTER XI	
THE EYE AS AN INSTRUMENT OF TELEVISION	165
Adjustments of the Eye—Viewing a Television Reproduction— Effect of Color—Brilliance—Interfering Illumination—Advan- tages Gained by Projection—Necessity for Uniform Detail—Eye Response to Motion—Persistence of Vision	
CHAPTER XII	
DETAIL REQUIREMENTS OF TELEVISION REPRODUCTION	181
Definitions—Determining Eye Requirements for Detail—Basis	

CONTENTS

	PAGE
for Establishing Television Detail Requirements—Resolving Power of the Eye—Picture Elements Required for Scenes of Various Dimensions and Viewing Distances—Detail in Motion Pictures Analyzed—Channel Requirements for Television of Various Degrees of Detail—Minimum Requirements for Permanent Entertainment Service	
CHAPTER XIII	
PROGRAM POSSIBILITIES OF TELEVISION	206
Early Programs Restricted by Technical Limitations—Television as a Supplement to Sound Broadcasting—Possibilities of Crude Television Systems of Moderate Detail—Broadcasting Studio as Source of Television Programs—Possibilities of 100-Line Television—Variable Repetition Rate and Detail—Television of Motion Pictures	
CHAPTER XIV	
COMMERCIAL POSSIBILITIES OF TELEVISION	222
How Advertiser Will Utilize Television—Structure for Economic Support of Television Broadcasting—Association of Television with Sound Broadcasting—Advertising by Television—New Types of Radio Advertising by Means of Television	
CHAPTER XV	
ESTABLISHING A TELEVISION ENTERTAINMENT SERVICE	233
Development of Broadcasting Compared with Television—Essentials to Television Meriting Public Support—Early Television Compared with Early Broadcasting—Taking Television out of Experimental Classification—Handling Sporting Events with Systems of Limited Detail—Association of Television Broadcasting with Reproducer Manufacture	
CHAPTER XVI	
INDUSTRIAL AND COMMERCIAL APPLICATIONS OF TELEVISION APPLI- ANCES	247
By-products for the Television Industry—Sound Motion Pictures—Facsimile Telegraphy—Features of Various Systems—Light Sensitive Devices in Industrial Control—Photoelectric Spectrophotometry	

CONTENTS

PAGE

CHAPTER XVII

FUTURE PROGRESS OF TELEVISION	258
Public Standards for Television Service—Broadcasting from Conception of Radio Telephony to Public Service—Electronic Control of Reproduction Illumination Essential—Channel Limi- tations Imposed by Continuous Progressive Scanning—Methods of Circumventing the Channel Limitation	
INDEX	267



TELEVISION

ITS METHODS AND USES

CHAPTER I

THE PRESENT STATUS OF TELEVISION

Television is a fitting crown to the achievements of this age of electrical development. The magnitude of its potential contribution to human well-being is alluringly foreshadowed by the startling accomplishments in the broadcasting of sound programs. Television promises even greater fruits because the visual sense is so thoroughly trained to receive, correlate, enjoy and remember an infinite number of impressions with great rapidity, as a result of our educational methods and our instinctive heritage.

The achievement of practical television is by no means a recent ambition. Since the human brain has been endowed with imagination, scientists have sought for the means to see beyond the range of the eye. The fundamental principles of modern television have been disclosed for more than half a century, and predictions that television would soon be an accomplished fact have been an unflinching avenue to newspaper publicity. The development of radio broadcasting has merely stimulated the output of such predictions.

TELEVISION

A third of a century ago Charles H. Sewall wrote:

The child born today in New York City, when in middle age he is visiting China, may see reproduced upon a screen, with all its movement and color, light and shade, a procession at that moment passing along his own Broadway.

A telephone line will bring to his ear music and the tramp of marching men. While the American pageant passes in the full glare of the morning sun, its transmitted ray will scintillate upon the screen amid the darkness of an Asiatic night. Sight and sound will have unlimited reach through terrestrial space.¹

Nature of Recent Developments.

The instrumentalities of television have recently improved tremendously by virtue of scientific progress in other fields, such as the electrical transmission of audible frequencies, photoelectric tubes, vacuum-tube amplifiers and motion-picture projection. But the well-established principles remain unaltered; the basic methods are only superficially modified. It is to the new tools of exquisite responsiveness and accuracy, replacing the crude instrumentalities of the pioneers, rather than to new fundamental inventions, that we owe our recent progress.

Realizing the enthusiasm with which the public will greet a television service offering visual programs of real educational and entertainment merit, a vast amount of inventive talent and enormous research facilities have been concentrated upon its development. Not only is the general public enthusiastic, but a highly developed radio industry eagerly awaits

¹ SEWALL, CHARLES H., *The Future of Long Distance Communication*, *Harper's Weekly*, December 29, 1900.

THE PRESENT STATUS OF TELEVISION

the day when it may offer a newer and greater service by broadcasting television programs, and by making and selling the paraphernalia essential to their transmission and reproduction. The opportunity for service, distinction and profit, offered by television, has been clearly foreshadowed by the achievements of its predecessor, sound broadcasting. The long-awaited day of television's practical graduation to the status of a public service will indeed be a milestone in the lives of men and industries. It is natural that the most persistent question asked in regard to television is, when will television emerge from the laboratory and make its bow as an acceptable entertainment service?

When Will Television Arrive?

That question is not easily answered. Year after year, those commercially interested in its future have stated that television is "just around the corner." Admittedly, the recent accomplishments of coordinated research in the field merit confidence and enthusiasm. The veritable avalanche of research concentrated upon the solution of the remaining problems of television lends force to the prediction that practical television is soon to be an accomplished fact.

How near we are to that achievement cannot be accurately determined from the exaggerated press reports which accompany each forward step. If we had a definite method of evaluating the performance of television transmitters and reproducers, it would be much easier to appraise the significance of each development and to determine how much of the road still remains to be traveled. However, the program

TELEVISION

and performance requirements of a television reproducer which will merit public support can be analyzed in fairly specific terms. With this standard defined, the capacity of the terminal apparatus and the magnitude of the communication channel necessary to link transmitter and receiver can be determined. As one improvement follows upon another, we can then accurately appraise the significance of every step forward, and thus forecast more nearly when television will leave the confines of the laboratory and make its way into the home.

Many Elements of Television Fully Developed.

As we familiarize ourselves with accomplished developments, we shall find that an impressive part of the work of the laboratory technician has already been accomplished. Many of the elements of the television system are highly developed and fully capable of doing their part in producing and reproducing detailed moving images. A major invention which effects a radical conservation of radio channel requirements will provide a considerable impetus to the commercial progress of the art. In fact, if television is to be accomplished through radio broadcast transmission, such an invention is quite essential to material progress in the science.

Every great invention has faced such obstacles. Radio telephony and broadcasting remained in the embryo stage for a decade, awaiting a practical system of carrier modulation; the automotive industry marked time until an adequate highway system spread its network over the land; long-distance telephony needed the vacuum-tube relay before it could come into

THE PRESENT STATUS OF TELEVISION

its own. Each of these steps in progress was a major corner which had to be turned before real commercial success could be possible. The most important problem of television is a reduction of the burden which it places upon communication channels for sending an image of a given detail. Television will turn its corner when an image can be reproduced and maintained without requiring an extremely liberal communication channel for a given number of picture elements per second.

Fundamental Definitions.

Television is the remote and sustained reproduction of an active scene simultaneously with its presentation, transmitted to one or more remote points by means of electrical communication. It is the electrical transmission of what the eye sees at one point and its reproduction at one or more distant points. The subject of the transmission may be a news or sporting event, a specially staged entertainment or educational program, or a scene viewed from a vehicle on land, on sea or in the sky. The broadcasting of a motion picture is known as motion-picture television or telemovies.

The term *television* is now being used to refer specifically to the transmission and reception of moving scenes by radio. It is considered misleading to use the term in connection with demonstrations in which transmission is accomplished through wire circuits. Such television, at least at this stage of the art, is properly referred to as *wire television*, in order to indicate that the problems of radio transmission and synchronization without the aid of special wire cir-

TELEVISION

cuits or power interconnection are not involved. However, should general service be inaugurated, using guided radio-frequency transmission over power or telephone systems, this technical limitation of the term television to radio methods is not likely to be maintained.

Picture transmission, phototelegraphy or facsimile transmission, is similar to television in that a reproduction is made of a scene or illustration remote from the transmission point. The effect of continuous motion, however, is not secured, the elements constituting the reproduction being progressively assembled upon photographic paper over a comparatively long period of time. The reproduction with phototelegraphy is not viewed simultaneously with transmission, but must be built up by collecting light impressions through photochemical processes or by means of other chemical changes directly or indirectly controlled by light. The reproduced field of view cannot be observed in its entirety until after the transmission has been concluded, and the result constitutes a permanent photographic reproduction of the field of view.

The *field of view* is the area or space to which the television pick-up system responds and within which the subjects of a television transmission are confined in order to be within the purview of the light sensitive element or "eye" of the system.

CHAPTER II

HEARING, VISION AND TELEVISION

Since television is the radio transmission and reproduction of a representation of the field of view of the human eye, or a substantial part of it, at a speed sufficient to permit its simultaneous and continuous reproduction in uninterrupted motion, it is a form of communication. Any communication is founded upon a sense impression as perceived by the human apparatus; that impression is adapted by special equipment to the requirements of a transmission medium, such as a radio or wire channel, and, after propagation through it, the impression is reproduced in a form which appeals to the original sense response.

Nature of Communication.

Even simple speech between two persons involves a chain of conversions, each of which must be completely and successfully carried out if the communication is to be successful. Speech starts with a nerve impulse set up as a result of a thought in the brain of the speaker. The transmission medium in the case of speech is the air. The thought of the speaker is converted by the vocal system into variations of air pressure according to arbitrary sounds which constitute our language. If these air-pressure impulses fall upon a human eardrum, its mechanical response is perceived by the brain as sound.

TELEVISION

Inventive genius has greatly extended the range of our various forms of sense response. The limitations of our vocal system have been extended to the ends of the earth by the successful feat of converting the air-pressure impulses into electrical impulses, in which form they are readily distributed through two widely used transmission mediums, radio carriers and wire networks. It is essential in all communication systems that each conversion system and each transmission medium shall preserve the essential elements of the reproduction. Each link of the chain must be capable of carrying the entire burden of essential elements involved in reproduction.

It is but natural that we should seek to communicate visual images through the same transmission mediums used for speech and message communication because of the comprehensive character of the information which can be conveyed by the sense of sight. The superior efficiency of our visual impressions over our auditory ones, so far as the rapid conveyance of comprehensive information is concerned, can be judged by considering the relative plights of a blind person and a deaf person. The former is strictly limited in his contacts with the world and robbed of a tremendous proportion of appreciation of it, while the deaf person can indulge in a great variety of occupations without special training.

The Problem of Sound Communication.

The fundamental difficulty, which enormously complicates the consummation of successful television, is due to the complexity of the sense impressions which are successfully responded to, correlated and observed

HEARING, VISION AND TELEVISION

by our visual system. Response to sound is infinitely more simple. Air-pressure impulses bear a simple relation to time. The pressure exerted on the eardrums at any instant is only a single value. Although an orchestra consisting of several scores of instruments may contribute to sounds at a given point, the air impulses which each instrument sets up combine with the impulse emanating from the others in a single impression which, at any instant, is represented by a single condition of air pressure.

Therefore, in sound communication, we undertake the relatively simple task of transcribing a phenomenon which, at any one instant, consists of but a single condition. It is true that air-pressure variations may occur at a high frequency, requiring a communications system capable of accommodating a broad band of frequencies. A system, able to handle up to a maximum of eight thousand accurately controlled impulses per second, is sufficient to permit remarkably faithful reproduction of the most complex music. That is why so simple a system as an electrical circuit, to which a fixed potential is applied, serves as a satisfactory transmission medium for sound impressions. With this facility, it is necessary merely to vary the resistance of the circuit in accordance with speech sounds at one point to transmit speech. A microphone is a type of resistance which varies according to the air pressure imparted to the diaphragm by a speaker. Now that we have vacuum-tube amplifiers at our service, there are no limits (other than economic or commercial limitations) within terrestrial space for any desired form of speech or musical communication.

TELEVISION

The Magnitude of Visual Communication.

The problems of visual-image transmission are vastly more difficult. We do not deal with a single series of conditions, as with sound. The eye receives a separate and identifiable impression from every point within its field of view at all times. It is able to respond to a vast number of such impressions at the same time, discriminating their individual (1) frequency, which determines color, (2) intensity, and (3) direction. The eye is able to compare and correlate the arrangement of these impressions geographically not only so as to determine size, form and relation, but, by a comparison of what is seen by the right eye with what is seen by the left, their perspective arrangement.

If we attempt to resolve the constituents of a scene which the eye perceives and the brain collates into a comprehensive and intelligible scene into its separate elements, it would be found to comprise perhaps a hundred million elements. Indeed, so vast is the number of simultaneous impressions to which the visual system responds, that we have keen powers of visual concentration and selectivity, much keener than those possessed by any other sense. We habitually hear all the sounds within the range of the auditory system and, with the utmost difficulty, exclude sounds of major volume to give preference to others of minor volume. With vision, however, in order to relieve the brain of unessential discriminations, we can readily reduce the field of view by adjustment of the lens system; we can consciously select definite frequencies or colors out of the vast maze of

color and raise the sensitivity of the eye for any particular image at will.

Comparison of Sound and Visual Communication.

The human vocal system can originate a vast range of sounds; specially trained persons can actually imitate almost any desired sound, the only real limitation being volume. It is significant that nature has evolved only a receiving system for visual impressions, and that there is no organism capable of originating visual impressions at will, as we can set up or imitate sound impressions. The equivalent of television transmission is a function which kindly nature decided to be non-essential, perhaps to avoid burdening the brain with too complex a labor, or perhaps in despair that such an apparatus could be included in the human anatomy without sacrificing the power of locomotion.

One of the fundamental considerations which must be determined in evaluating television is what constitutes the communication of sufficient visual information to be practically useful. With such an enormous range of possibilities afforded through our visual sense, it is necessary, naturally, to make tremendous sacrifices in the scope of the field of view and the detail and character of impressions selected for television communication. With our present knowledge of the art, we can conceive only systems which confine themselves to the communication of but a small proportion of the elements naturally observed by the eye.

The fundamental difference, then, between the magnitude of the problem encountered in the transmission of visual images and in that of speech is that visual images, as perceived by the eye, are, at any

TELEVISION

instant, numerous, and therefore require that we secure the effect of simultaneous transmission of parallel impulses. Furthermore, relative direction and elevation of these impulses must be accurately maintained to secure a comprehensive reconstruction of the field of view. Loss of direction in sound communication, such as that involved in reproducing an 80-piece orchestra (ordinarily heard from a broad range of directions) from a single point, the loudspeaker, is accepted without comment by a satisfied audience of radio listeners. With sound transmission, we need only a simple linear system, consisting of a definite succession of impulses, accurate as to frequency and intensity. With television, we must accommodate a vast number of parallel impressions, convert them into a simple series, and then provide means of rearranging these numerous impressions in their proper parallel arrangement at the point of reproduction. Therefore, television imposes tremendous loads upon communication channels, whether wire or radio, if a reasonably comprehensive reproduction is to be attained.

Appraising Progress in Television Development.

Television development can be readily evaluated by determining the extent to which the distant reproduction differs from the original scene. Every television reproduction sacrifices many of the elements perceived by the eye. The specific character of the most important departures from faithful reproduction is readily classified into four major groups as follows:

1. Color: Elimination of the distinction of wave frequency which results in color differences.

HEARING, VISION AND TELEVISION

2. Size: Restriction of the field of view to a small area.

3. Detail: Reduction of the number of picture elements into which the field of view is broken down.

4. Repetition: Reduction of the number of repetitions of the complete scene to the minimum which will secure the effect of continuous motion.

It is necessary to understand the effect upon the potential entertainment and educational value of a television reproduction in the light of each of these curtailments. The fact that faithful reproduction is not attained by any television system is no reflection upon the progress of that science. Every artificial system of communication involves some sacrifice. The most advanced methods of artificial musical reproduction completely sacrifice the factor of direction of sound which contributes to the enjoyment of orchestral music and simplifies the identification of the person speaking on the stage. A telescope, while not a system of communication, achieves its purpose of bringing distant images nearer by proportionate sacrifice in the extent of the field of view. The departures from faithful reproduction in television must be studied only from the viewpoint that they may be too drastic to permit the final result, the distant reproduction, to justify itself by its educational or entertainment value in the light of the cost required to attain it.

Elimination of Color Discriminations.

Elimination of the distinction of frequency is very widely employed in all manner of visual image communication and recording. Photographic prints are records of the intensity of light as reflected from a

TELEVISION

given scene properly arranged. Loss of color involves but little sacrifice of usefulness in most types of illustration because the memory and imagination readily supply the missing element. Motion pictures, for instance, possess adequate entertainment and educational value for most practical purposes, although they are rarely in color. A highly satisfactory television service is conceivable without introducing the element of color.

Reduction of the Extent of the Field of View.

Reduction of the field of view can effect a marvelous saving in the task imposed upon a television system, although that practice can also be carried too far. For example, a dramatic service rendered by television would possess little attractiveness if the capacity of the system were limited to the portrayal of the facial expression of a single individual. A television reproduction of the busts of two persons would still possess little dramatic possibility, although it would represent a vast improvement over the transmission of a single face. The reproduction of three full-length figures with background in suitable detail, on the other hand, would permit the handling of many dramatic situations and would therefore possess considerable entertainment value.

Sacrifice of Detail.

The detail required is somewhat influenced by the subject matter to be transmitted. The half-tone method of printing, as used for illustration purposes in books, is an excellent means of judging the effectiveness of television systems. With practically all

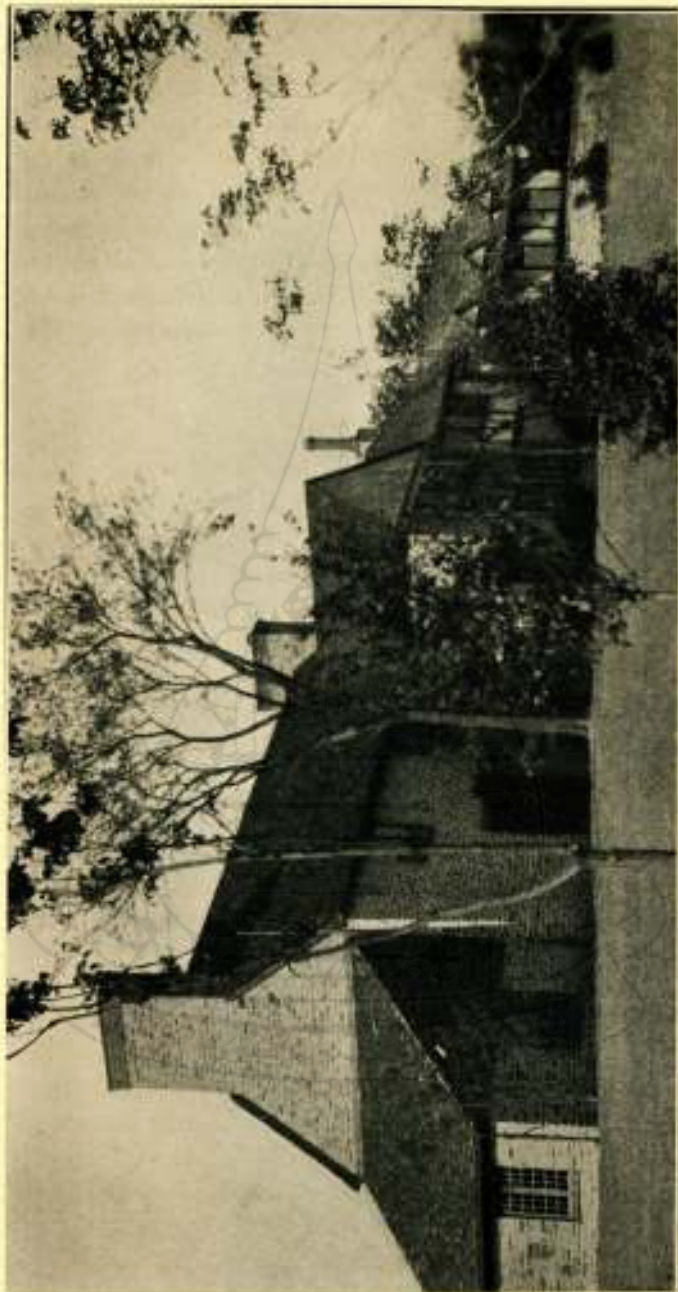

FIG. 1.—Each square inch of a half-tone illustration of 133 screen has 17,680 separate elements. This reproduction shows the detail attainable with 133 screen.



FIG. 2.—The same scene reproduced with 100 screen, or 10,000 elements per square inch. Despite the substantial reduction in the number of elements, the sacrifice of detail is moderate.

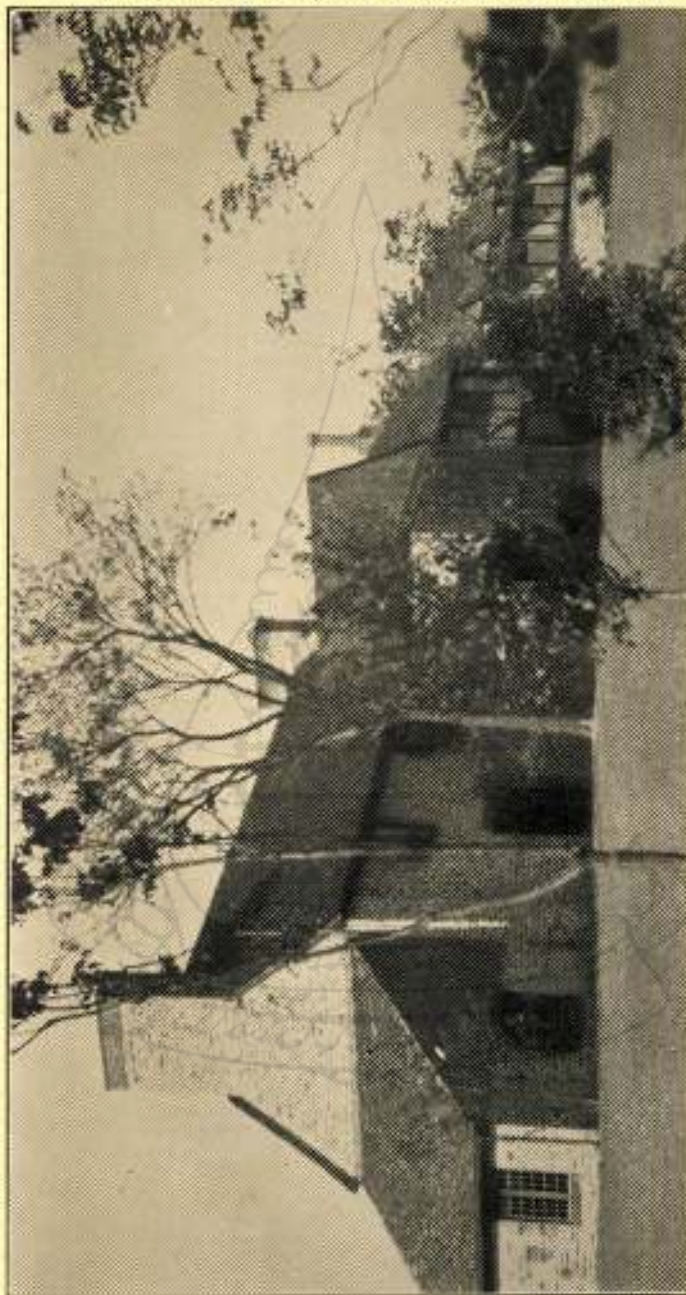

FIG. 3.—At 55 screen, an average value in newspaper reproduction, all fine detail in the scene disappears. This is equivalent to 3,025 elements per square inch.

TELEVISION

systems of television reproduction, there is some improvement in detail over a half-tone of the same area and the same number of picture elements because, in a half-tone reproduction the shading of only half the area is controlled by the field of view, much of the scene being excluded by the screen, while the television reproduction is usually a composite of controlled picture elements covering the entire field. The usual newspaper half-tone consists of 55 to 65 screen, *screen* being used to indicate the number of dots per linear inch. Figures 1, 2 and 3 show the same illustration in various values of screen, illustrating the effective sacrifice in detail resulting from reducing the number of impressions which compose the illustration.

Some indication of the striking sacrifice in detail which may be made without substantial loss in information value to the eye is given by comparing the number of picture elements in the reproductions on pages 15, 16 and 17. If a television reproduction, 4 to 5 inches in size, of the same number of impressions as given in these half-tones were possible, visual programs of a wide range of interest would be entirely within its capabilities. The 133-screen picture of that size consists of 353,780 impressions. By reducing to 100 screen, no vast sacrifice, the number is cut to 200,000. In the case of the rough newspaper-screen illustration, the number of impressions in a 4 by 5 reproduction may be but 50,000. The marvelous detail of photographic processes, due to fine division by individual chemical action contributing to the texture of a photograph, is indicated by the fact that a 4 by 5 photographic reproduction may involve as many as 100,000,000 separate impressions of light and shade.

The Repetition Rate.

The number of times per second that the subject matter must be scanned to secure the effect of continuous motion is a function of the persistence of vision. The eye's perception is relatively instantaneous, but an impression made upon the retina endures up to as long as a tenth of a second after the disappearance of the subject. The intensity of illumination and the contrast in the subject influence the time period during which we may rely upon persistence of vision. The first motion pictures consisted of 16 reproductions per second. Although this number gives the impression of continuous motion, the flicker experienced is fatiguing. As a result, the modern standard is 24 reproductions per second. Television transmissions with 12 and 15 repetitions per second have been attempted, but 18 appears to be the minimum for slow-moving subjects, and a still higher rate is required for rapid motion.

Specifying Television Transmission Quality.

In view of the variety of ways in which the information selected for television transmission may be curtailed, there is a wide latitude in the quality of the picture signal radiated by the television broadcaster. With its present knowledge, the public cannot analyze the factors controlling the attainable quality of reproduction, but in the end the popularity of television features will depend as much upon the density of picture elements, the extent of field of view and the repetition rate as it does upon the subject matter being broadcast. Merely to state publicly that a scene from an airplane is to be "televised" or that the

TELEVISION

inauguration of a president will be served to a vast army of short-wave television observers is in itself quite meaningless unless we know how extensive is the field of view being televised, into how many picture elements the scene is resolved, and how high the repetition rate. Television promoters have freely taken advantage of the gullibility of the public and the press by promising to televise such events, presumably with 24- or 48-line systems, although they must be aware that such comprehensive scenes, to be of the slightest service value, require a television system of vastly greater capacity than has yet been devised. The sooner the practical meaning of density of picture elements and extent of field of view is generally understood, the sooner will television publicity be founded on honest representations.

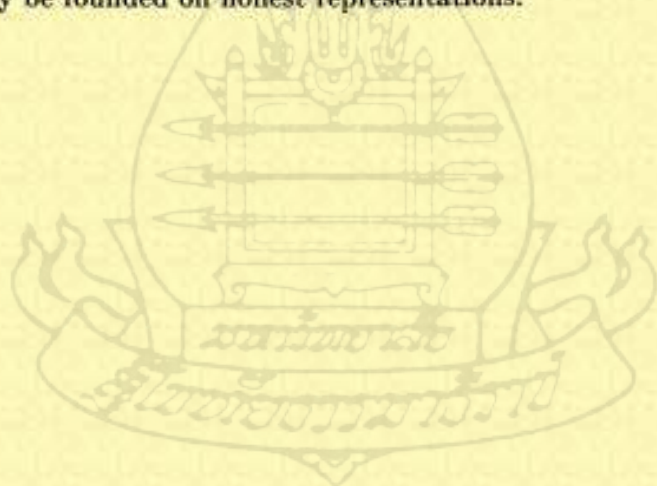

CHAPTER III

THE SIX PROCESSES OF TELEVISION

Before proceeding with a detailed study of the subject, it is of advantage to learn the general processes of television. We are as yet unable to transmit the entire subject of the field of view as a single electrical impulse. Therefore it is necessary to break down the subject of transmission into a succession of finite areas or *picture elements*. The total number of picture elements determines the detail attainable in reproduction and the character of the subject matter which may be transmitted.

Scanning.

Breaking up the field of view into an orderly succession of picture elements is called *scanning*. Scanning is usually accomplished by a rotating disc in which a series of apertures has been cut in a spiral arrangement. Observed at any one point through a frame behind the disc (Fig. 4), the light reflected from the field of view becomes a series of horizontal sweeps which progressively break down the field of view in parallel rows. The entire field of view is scanned by a complete revolution of the disc. The horizontal dimension of the field at any specific distance from the scanning disc is determined by the spacing between the successive holes of the spiral and the vertical dimension by the depth of the spiral. Each hole of

TELEVISION

the scanning disc scans a line or row of picture elements horizontally across the field. A television system using a 24-hole disc is therefore referred to as a 24-line system, a 48-hole disc as a 48-line system and so on.

Speed of scanning must be sufficiently rapid to secure the effect of smooth motion. This requires at least 16 and preferably not less than 20 reproductions of the field of view per second. Since one revolution of the conventional disc accomplishes one scanning of the subject, the customary scanning disc speeds lie between 960 and 1,200 revolutions per minute.



FIG. 4.

The Light-sensitive Element.

Having broken down the subject matter of the field of view into a succession of light impulses, arranged in a predetermined order, we then convert these impulses into electric current variations by means of a *photoelectric cell* or other *light-sensitive device*. The photoelectric cell is a vacuum tube, the output of which varies, when proper potentials are applied to it, in accordance with the amount of light reflected upon it. By directing the light reflected from the

THE SIX PROCESSES OF TELEVISION

field of view to a photoelectric cell through the scanning disc, we secure a progressive electrical intensity record of the subject matter to be transmitted. An electric current, representative of a series of visual impressions, is called a *picture signal*. The cooperation of the scanning system and the light sensitive element secures an electrical counterpart of the field of view analogous to that obtained in sound transmission by the microphone at a broadcasting station.

The Picture Signal.

Picture signals may be transmitted over distances through wire circuits or radio transmission channels, provided they are not of such a high frequency as to impose loads too great for such channels to accommodate. They may be recorded on phonograph discs or sound film for future transmission, if the recording device is of sufficient capacity to respond to the essential range of frequencies in the picture signal. Using our conventional methods of radio transmission and reception, we are able to reproduce the picture signal generated at the transmission point at any number of desired reception points. The final step in reproduction is to convert the picture signal thus intercepted into equivalent light variations arranged in their correct relative positions, so that they can be enjoyed by the observer at the distant point.

The Light-producing Element.

In most instances, a neon tube is used to restore these electrical impulses to equivalent light intensity variations. The illumination on the surface of the plate of the neon tube varies in accordance with the

potentials applied to it. The size of the plate determines the overall size of the reproduction secured. The surface or area upon which the reproduction is accomplished is called the *field of reproduction*. In order to reconstruct or reproduce the transmitted image, we reverse the scanning process.

The Receiving Scanning Disc.

Interposed between the eye and the relatively large plate is a scanning disc with the holes arranged in the same way as those of the scanning disc used for trans-



FIG. 5.

mission. It is essential, to secure an intelligible reproduction, that the reproducing scanning disc revolve at precisely the same speed as the scanning disc used to divide the subject of transmission into a series of picture elements. The method used to maintain transmitting and reproducing discs at the same speed is called *synchronization*. The purpose of the reproducing scanning disc is to restrict observation of the illumination of the neon tube to the particular area corresponding to the signal representative

THE SIX PROCESSES OF TELEVISION

of the picture element being transmitted at the moment.

The transmission may start with the picture element in the upper right-hand corner of the field of view. If that particular area is the brightest value of the subject, a maximum impulse is transmitted, causing the reproducing neon tube plate to brighten over its entire surface to its maximum intensity. Because the proper hole of the receiving scanning disc is then exposing only the upper right-hand corner of the plate, maximum intensity of illumination is observed only at that point, although the entire field of reproduction is so illuminated. As the transmitting scanning disc revolves, its outermost hole passes progressively across the top of the field of view, while the corresponding area of the plate of the neon tube at the receiving point is likewise exposed. The light intensities reflected on the light-sensitive device are translated into corresponding light-intensity variations of the neon-tube plate. The scanning disc hole restricts the observation of these intensity fluctuations to their correct position in the reproduction.

After the outermost hole of the scanning disc has passed over the edge of the neon-tube plate, the second hole, slightly lower, comes into position at the left, sweeping another row, slightly lower than the first, across the neon-tube plate. The succession of holes in the disc covers the entire surface of the plate in one revolution, thus completing one reproduction of the subject. The process is accomplished with such rapidity that the eye, because of the persistence of vision, instinctively collates these successive light impressions into a complete image.

TELEVISION

The Six Processes of Television.

To sum up: Television transmission and reception involves the processes listed below. The elements accomplishing these processes are given in the second column.

Function	Device
1. Resolution of the field of view in an orderly arrangement of picture elements	Transmitting scanning disc
2. Conversion of a series of light impulses thus secured into electric current	Light-sensitive element
3. Transmission through space by radio	Radio transmitter
4. Reception with radio receiver and restoration to electric current impulses	Radio receiver
5. Conversion of resultant impulses to light	Neon tube
6. Arrangement of light variations in correct position	Receiving scanning disc synchronized with transmitting scanning disc

Each of these progressive steps in television has been demonstrated by at least several methods. The progress already achieved is sufficient to encourage the hope that practical commercial television will soon be evolved. Furthermore, public enthusiasm, even in the crudest preliminary demonstrations, indicates such a demand for practical commercial television that there has been tremendous concentration of scientific forces, working toward its ultimate accomplishment.

Commercial Television.

In order to aid in judging the merits of television systems as they are demonstrated, a special committee

THE SIX PROCESSES OF TELEVISION

of the Radio Division of the National Electrical Manufacturers' Association, comprising some of the leading scientists working in this field, has prepared a definition of commercial television. This is not an attempt to set a standard but only to describe some of the principal elements of a television system which will have public appeal on the basis of the entertainment and educational service rendered rather than through its curiosity or experimental value. The definition is as follows:

Commercial television is the radio transmission and reception of visual images of moving subjects, comprising a sufficient proportion of the field of view of the human eye to include large and small objects, persons and groups of persons, the reproduction of which at the receiving point is of such size and fidelity as to possess genuine educational and entertainment value and accomplished so as to give the impression of smooth motion by an instrument requiring no special skill in operation, having simple means of locating the received image and automatic means of maintaining its framing.

A Typical Television System.

In order to clarify further the various steps in the process of television, consider the system shown in Fig. 6. The subject stands within the field of view, brightly illuminated by high-intensity arc lights in order that the maximum lights and shadows shall be reflected from his person. The scanning disc disintegrates the field of view into successive impressions by progressively exploring the surface of the face. Light is thus reflected to the photoelectric cell from one picture element at a time. An amplifier builds

TELEVISION

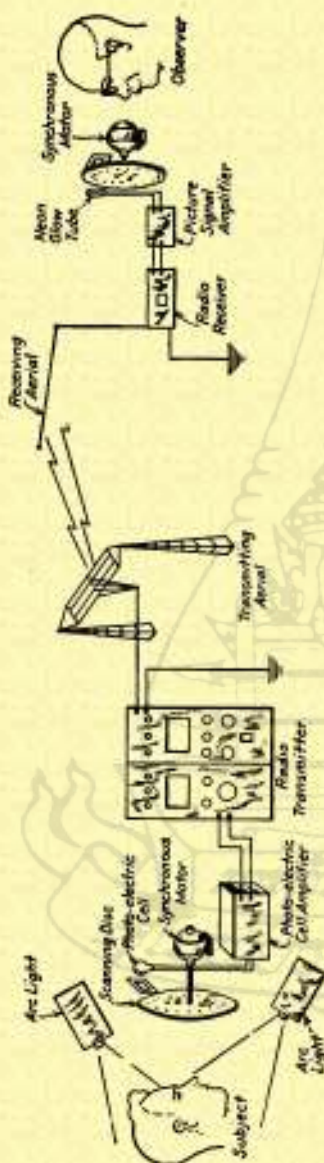

FIG. 6.

up the electrical counterpart of the light intensities observed until they are of sufficient magnitude to be combined with the carrier of a radio station and transmitted through space. The radio receiver, adjusted to the frequency of the carrier, amplifies and then isolates the picture signal impressed upon the carrier through the usual radio-frequency amplifier and detector circuits. The picture signal is then amplified to values sufficient to cause light fluctuations in the neon tube. The receiving scanning disc is rotated by a motor in synchrony with the motor rotating the scanning disc at the transmitting point. Some means of synchronization is employed to keep these two scanning discs in absolute unison so that, when the photoelectric tube is indicating the light intensity for a

THE SIX PROCESSES OF TELEVISION

certain area of the field, that particular area is the one being reproduced at that instant. The eye collects the series of varying light impulses as a complete image, provided the system repeats the transmission and reproduction of the field at least sixteen times a second.

The apparatus, so far described, is stripped of all but its bare essentials and is discussed at this point only in order that the separate elements of television systems may be defined and considered in detail as individual units. This procedure is followed in preference to describing the work of individual inventors because, undoubtedly, the first commercial television system which has any widespread vogue will be a combination of the devices of many inventors. We will consider separately such devices as light-sensitive units, of which the photoelectric cell is but one of several available types, scanning discs, amplifier systems, synchronizing methods and methods of reconstructing the image. The crude system already described will make it possible for the reader to consider each functional element in detail without losing sight of its relation to the television system as a whole.

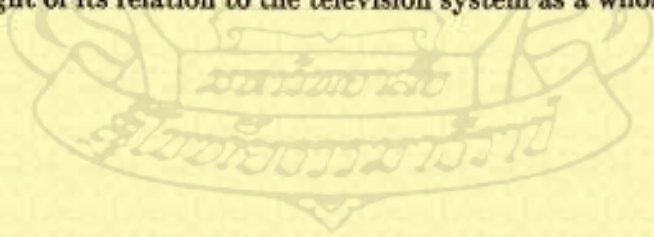

CHAPTER IV

SCANNING THE FIELD OF VIEW

Purpose of Scanning.

The purpose of scanning is to present small units of the field of view to a light-sensitive element in an orderly progression so that a series of electrical impressions of light intensity, suited to wire or radio transmission, may be secured.

Lines and Picture Elements.

Most scanning systems accomplish their purpose by dividing the field of view into a succession of parallel sweeps or lines, beginning at the top of the field and continuing progressively to its base. Such scanning systems are rated in "lines," e.g., 24-, 48- and 100-line systems. Each line is divided into an arbitrary number of picture elements. The number of picture elements per line is calculated by dividing the effective diameter of the scanning aperture into the length of the arc through which it sweeps while scanning each line. If the field of view is square, the number of picture elements into which it is divided is the square of the number of lines. Thus a conventional 24-line system divides the field of view into 576 elements, a 48-line system into 2,304 elements, and a 100-line system into 10,000 elements.

The rapidity with which the scanning process is carried out is at the root of the major problems of

SCANNING THE FIELD OF VIEW

television. The entire scene must be scanned within the short period that the eye can collate the separate picture-element impulses into a complete and unified image. As soon as we increase the number of lines to values approaching commercial standards, we are faced with the need for a tremendously rapid parade of picture elements to which the entire communication system must be responsive. For example, with a 100-line system and 20 repetitions per second, we are concerned with 2,000,000 picture elements per second.

Necessity for Scanning.

This disintegration of the field of view by a scanning system is necessary because we have discovered no way of analyzing our complete subject matter simultaneously in a manner that permits the retention of its detail. Were we to attempt the transmission of the light intensity of a field of view as a single impression by our present methods, we would secure a result analogous to that obtained by looking at the whole field of view through a ground-glass window or any translucent but non-transparent material. The resultant electrical impression of the light intensity of the field of view is only an average value of light which is reflected from it, and its reproduction would portray little or nothing of value to a distant observer.

In the absence of such a convenient method of securing an impression of the entire field of view in all its detail in a single operation, we break up the field of view into a series of picture elements and transmit an electrical impression representative of the light intensity of each element in a regular and

orderly progression. At the reproducing point, we control the intensity of a light source in accordance with these impressions and reconstruct the field of view by projecting or exposing the controlled light through the same progressive course followed in the original scanning or by limiting our observation of the light source so that the equivalent effect is secured.

Progressive Observation and Progressive Illumination.

There are two fundamental methods of submitting the subject to the light-sensitive element: first, the progressive observation of picture elements, one at a time, through a scanning disc, and second, the progressive illumination of the field of view, picture element by picture element, by means of a moving pencil or beam of light.

In the first case, the field of view is intensely illuminated in order that the maximum light energy may be focused from each picture element of the field of view to the light sensitive element. The conventional spiral scanning disc, due to Nipkow, which has already been described, accomplishes the disintegration of the field of view and restricts the response of the light-sensitive element to one picture element at a time. The amount of light reaching the light-sensitive cell is dependent upon the illumination of the subject and the effective apertures of the optical system and of the scanning disc or other device used to collect light from the subject matter.

The alternative method is to explore the field of view by means of an intense beam of light. The light sensitive cells are placed in such a manner as to collect light from the entire field of view. When the exploring

SCANNING THE FIELD OF VIEW

beam of light is focused upon a white part of the field of view, the maximum reflection occurs, causing maximum output from the light-sensitive system; when the beam is focused upon a black part of the field of view, the light is absorbed, causing the light-sensitive system's output to fall to a minimum. Consequently, the exploring light has the effect of increasing the light falling on the photoelectric cell above the average reflection proportionate to the brilliancy of the picture element being explored at each particular instant.

Progressive Observation of Picture Elements.

With the progressive observation system, the amount of light actuating the light-sensitive element is limited to that reflected through a relatively small aperture. To secure an adequate response, it is necessary to illuminate the subject matter by means of extremely powerful lights and to paint the faces of actors in a grotesque manner. It is reported that Baird used arc lights of such intensity with his first experimental television transmitter that only dummy figures could be used as subject matter.

The amount of light collected from each picture element can be increased by using a large collecting lens, but physical difficulties prevent increasing the diameter of such lenses with respect to focal length beyond a certain ratio. When the area of the image is increased beyond a certain point, a considerably larger scanning disc is necessary. Considerations of mechanical convenience therefore limit the size of the collecting system which may be employed.

Experiments show that, with the best lens available to form an image 1 inch square, the subject matter

must be illuminated with a 16,000 candle-power arc light at a distance of 4 feet in order to secure an image bright enough to cause a light-sensitive cell output sufficiently large to override the noise level of the associated amplifier system necessary to build up the picture signal for transmission purposes. A photoelectric cell of the usual type, with an opening 1 inch in diameter, will give a current of a microampere in response to a 25-watt lamp 4 feet distant. Improvements in the sensitivity of photoelectric devices may, of course, materially alter this situation at any time. However, so long as we are confined to light-sensitive devices of the present order of sensitivity, tremendously powerful illumination of a restricted field of view is necessary when a progressive selection system of scanning is used.

Overriding Random Voltages in Coupling Resistors.

When the light energy from the field of view is focused on the light-sensitive device in small units, the current variations resulting are naturally extremely small. Most light-sensitive devices, particularly of the photoelectric type, possess very high resistance, requiring that the output of the cell be coupled through a proportionately high resistance to actuate the first amplifier tube. In any piece of metal, the electrons are constantly in a state of rapid motion, resulting in minute and rapidly changing voltage differences at their ends. When extremely high amplification, of the order necessary when the output of the photoelectric cell is small, is applied to such resistances, these random voltages cause impulses which when reproduced in a television receiver resemble a phantom

snowstorm. This limitation is overcome only by intense illumination of the field of view or by a scanning system which produces large photoelectric current. The photoelectric current must be sufficient to override the random voltage variations experienced in any type of coupling resistance suitable for use with light-sensitive cells, as well as the familiar tube and circuit noises.

Effect of Large Scanning Disc Apertures.

The larger the diameter of the holes in the scanning disc, the more light is admitted but with the attendant disadvantage of blurring the detail of the picture. Supposing the field of view consists of a checkerboard, the sides of each square of which are equal to the diameter of the area analyzed by the hole of the scanning disc. The maximum value of light is reflected while the scanning system focuses the light-sensitive element squarely on one of the white squares, as shown in *a*, Fig. 7. In consequence, the reproducing system may be expected to reproduce full brilliance. Likewise, when the light-sensitive element is focused through the scanning disc precisely on a black square, as in *b*, Fig. 7, we transmit a signal equivalent to minimum light, causing the smallest light value at the reproducing point. But, midway between the extremes, instead of a sharp line of black as in the subject matter, we have a signal representing a half value, gray. When the scanning disc hole exposes an area one-fourth black and three-fourths white (*c*, Fig. 7), instead of securing a value of 75 per cent black or dark gray, as might be expected, the average light reflected is of a somewhat lower value, the

area scanned being circular. Due to these causes of distortion, the reproduction is far from a checkerboard, but rather a series of vertical bars, gray at the edge, darkening to black at the center and shading off to gray.

Slightly more accurate reproduction will be secured by using square apertures in the scanning disc. The intensity observed is then directly proportionate to the average values of black and white, without losses due to the reduced area of the entering and leaving

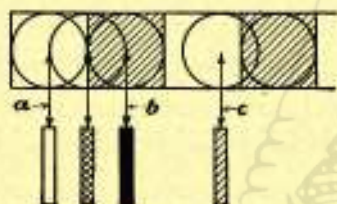

FIG. 7.—Effect of scanning a checkerboard pattern of a texture equal to picture elemental area.

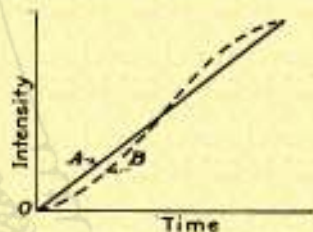

FIG. 8.—Effect of square- and round-disc apertures. *A* shows picture signal secured by scanning abrupt change from black to white through a square aperture; *B*, through the conventional circular-disc aperture.

edges of the scanning area. But the gain accomplished is not very great, as will be observed by the curve of Fig. 8. The mechanical difficulties of making a square hole in a spiral scanning disc are hardly compensated for by the improvement in reproduction which it makes possible.

In Fig. 7 we have assumed that the scanning disc is accurately focused upon each row of squares. Figure 9 analyzes the reproduction obtained when half the scanning line is on one row of checkerboard and half on another, while Fig. 10 shows the effect

SCANNING THE FIELD OF VIEW

of the diagonal set at a slight angle. These distortions are observed in actual practice. For instance, in scanning a close-up of a human face, the transition from one row to the next, as shown in Fig. 11,



FIG. 9.—Scanning a checkerboard pattern with the axis of the scanning path on the dividing line produces a medium-gray texture in every position.

will appear as a sharp jag in the reproduction of the lips when the mouth is at a small angle to the scanning line.

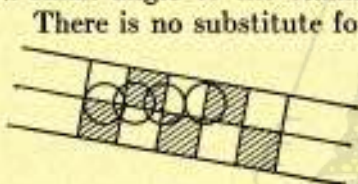

FIG. 10.—Scanning a checkerboard pattern at an angle to the squares tends to produce a medium gray in every position.

There is no substitute for picture elements in scanning. If intelligible information is to be conveyed to the eye by the reproduction, the scanning system must divide the field of view into a number of picture elements sufficiently large to satisfy the information requirements of the eye. The real recipe for securing accurate representation is to increase the number of picture elements analyzed so that no element of the subject matter which must be discriminated is less than the area of a picture element. This is equivalent in printing to using a half-tone of fine screen so that the detail is better reproduced.

There is no substitute for picture elements in scanning. If intelligible information is to be conveyed to the eye by the reproduction, the scanning system must divide the field of view into a number of picture elements sufficiently large to satisfy the information requirements of the eye. The real recipe for securing accurate representation is to increase the number of picture elements analyzed so that no element of the subject matter which must be discriminated is less than the area of a picture element. This is equivalent in printing to using a half-tone of fine screen so that the detail is better reproduced.

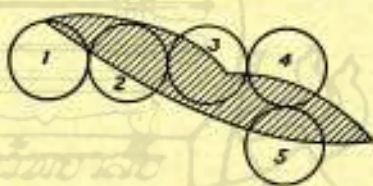

FIG. 11.—Scanning the human lips with a picture-element area equal to their maximum depth generally produces a jagged line.

Some idea of the detail attainable by a given scanning system can be secured by considering the size of a

unit-picture element in relation to the smallest detail which is essential to useful reproduction. In transmitting a page of print, for example, the dot of the *i* should be from two to four times the diameter of the unit-picture area in order to make it comfortably readable. If we transmit a close-up of a face, and desire to secure such details of facial expression as the wrinkles in the corner of the eye or those caused by the smile, such elements of the field of view must, in their shortest essential dimensions, be from four to eight times the unit-scanning element area. It seems unlikely that a permanent television entertainment service could be based upon a system which builds up a reproduction having less than a hundred thousand picture elements, regardless of the subject matter.

Progressive Illumination of Picture Elements.

When the exploring ray method is employed, the light-sensitive cell responds to the total illumination reflected from the entire field of view. The subjects in it, however, are not so seriously inconvenienced by the light source used, because only a tiny, though powerful, pencil of light, moving through the field of view with great rapidity, is observed. A system of this character, set up by the Bell Laboratories in 1927, utilized a 40-ampere Sperry arc condensed by a lens in the path of the moving apertures of a conventional spiral scanning disc having 50 small apertures and rotating 18 times a second. The three photoelectric cells used presented an area of 360 square inches to collect light instead of the maximum of 7 square inches of lens which could be used to form an image

SCANNING THE FIELD OF VIEW

through a 15-inch scanning disc. As a result, a substantial current output was secured, somewhat above the noise level of the amplifier systems used, without inconveniencing the subject by the intensity of the light required.

One of the features of the two-way television demonstration, conducted by the Bell Telephone Laboratories in June, 1930, was the use of a blue light beam for progressive illumination of the subject. The eye

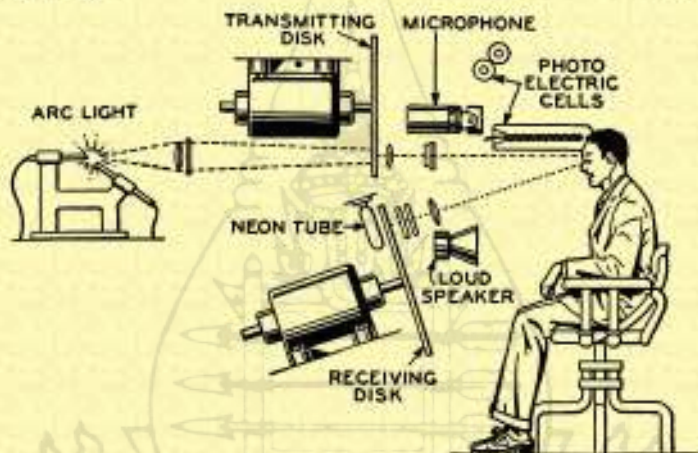

FIG. 12.—Schematic diagram of equipment used in demonstration of two-way television conducted by the Bell Telephone Laboratories.

is relatively insensitive to blue, while, by using special photoelectric cells particularly responsive to the light frequencies used, a substantial photoelectric output was secured with minimum inconvenience to the subject. Figure 13 shows the interior of the television booth with the photoelectric cell above and on either side of the speaker's seat. The pencil of light scanning the subject is directed through the

TELEVISION

circular aperture above the television reproduction of the speaker at the other end.

A further improvement in the 72-line pick-up system, made subsequent to the public demonstration, was the addition of a deep-red component to the



FIG. 13.—The booth used in the two-way wire television demonstration. The scanning light is projected to the subject just above the reproduction. The photoelectric cells are at each side and above the subject.

scanning ray, making the resulting light purple instead of blue. Two photoelectric cells of the caesium oxygen type very sensitive to red light supplement the sulphur

SCANNING THE FIELD OF VIEW

vapor type cells, producing marked improvement in the shading of the reproduction. Utilizing only the blue ray in scanning tended to make the reds and yellows in the face too dark in comparison with the whites, such as those of a man's collar. An incandescent lamp shown in Fig. 16 also replaced the arc formerly used for scanning.



FIG. 14.—The three major units of the apparatus used in the two-way wire television demonstration. The terminals of the photoelectric pick-up system are in the unit at the right; the scanning discs for pick-up and reproduction at the center and the arc light for scanning are at the left.

Advantages of Progressive Illumination.

While light-sensitive devices remain in their present status, the progressive illumination system has definite advantages over the progressive selection of picture elements. So long as the exploring beam is called

TELEVISION

upon to reflect light from subjects close to a bank of photoelectric cells, relatively large outputs are secured. We are looking forward, however, to commercial television which does not necessarily contemplate



FIG. 15.—By the addition of two caesium-oxygen cells on either side and a deep-red scanning beam, much greater naturalness in shading was secured subsequent to the public two-way wire television demonstration.

restriction of subject matter to close-ups and views of individuals. Inasmuch as the intensity of the light reflected to the light-sensitive unit as a result of the

SCANNING THE FIELD OF VIEW

exploring beam falls off as the square of the distance through which it travels, the ratio of light changes produced by the beam to total reflection falls off very rapidly as we expand the field of view. Consequently, the present popularity of the exploring beam or selective illumination method of scanning may be maintained only while the lack of sensitivity of light-responsive elements continues to limit us to subjects

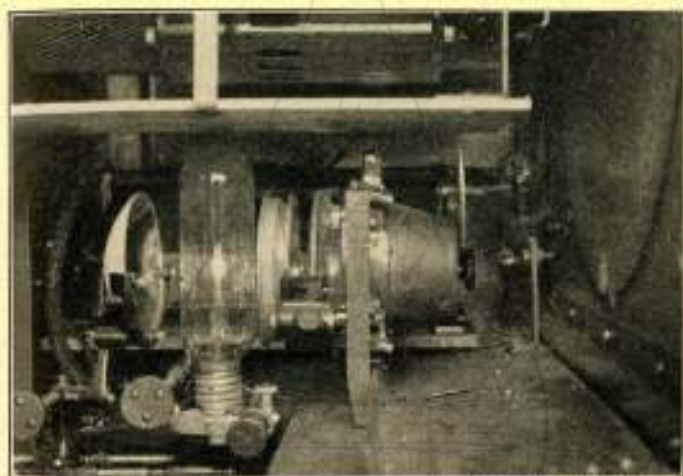

FIG. 16.—The incandescent-light source developed by the Bell Laboratories for scanning by the progressive illumination method.

placed close to such elements. When the ultimate is achieved in practical television, the scanning system and pick-up devices must reach the simplicity and practicability of the motion-picture camera, deriving sufficient illumination from the subject at a considerable distance in natural daylight to produce an adequate picture signal free of disturbing background.

Limitations of the Spiral Scanning Disc.

Up to this time, I have confined myself to describing the conventional scanning disc for disintegrating the field of view into a progression of picture elements. The spiral scanning disc, however, is only one sort of mechanical and optical system which accomplishes this purpose. It is distinctly limited in its field.

If the reproduction is to be observed without the aid of a lens system, the spacing between successive holes in the spiral is determined by the total width of the reproduction. As the number of lines and the width of the reproduction is increased to values approaching general service standards, we find that the scanning disc for direct observation quickly becomes of ungainly size and of dangerously high peripheral speed. A 100-line image of this character, 4 inches wide, would call for a disc of over 400 inches in circumference, or nearly 12 feet in diameter. This would obviously be unsuited to home use, particularly when it is realized that it must be revolved at a speed of 18 to 20 revolutions per second.

The diameter and peripheral speed difficulty is readily met by optical enlargement of a small image. But here we face a different set of difficulties. The more we rely upon optical enlargement, the smaller must the holes of the disc be and the greater is the effective distortion produced by any slight displacement of the holes. When a disc of small diameter having a spiral of several hundred holes is considered, its production in large quantities within the tolerances necessary constitutes an extremely difficult manufacturing operation.

SCANNING THE FIELD OF VIEW

The Prismatic Disc.

One of the developments in this direction is the prismatic disc, the development of C. Francis Jenkins, a pioneer worker in television in the United States. The prismatic ring is the equivalent of a glass prism which progressively changes the angle between its faces. When rotated, it gives a beam of light having a fixed axis from side to side in one direction and a hinged or oscillating axis in the other. Figure 18

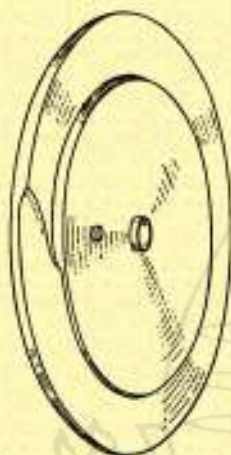

FIG. 17.—Jenkins' prismatic disc.

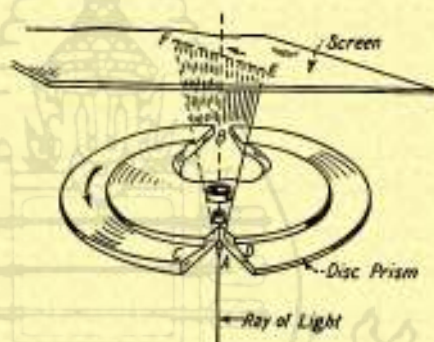

FIG. 18.—As the prismatic disk revolves, the image oscillates along path EF.

shows the area explored by a single prismatic disc. By employing two discs, one of which revolves many times faster than the other, the entire field of view may be explored. To secure a 100-line picture, for example, disc *A* may make 100 revolutions to each one of disc *B*. The subject matter of the field of view is thus covered by one complete revolution of disc *B*.

Lens-scanning Discs.

Jenkins has also constructed scanning discs employing lenses. The effect of the lens is to collect a multitude of light rays from a single picture element, focusing them upon the light-sensitive device. John L. Baird, the Scotch inventor, has used a similar system. By means of a revolving disc, carrying 16 lenses in stagger formation, images of the field of view are caused to pass over a second revolving serrated disc. This breaks up the light into a succession of impulses so as to suit them to electrical amplification systems. Behind this disc is another revolving at slow speed, having a spiral slot which passes in front of a longitudinal slot admitting light to a light-sensitive cell. The field of view is thus reduced to a series of impulses and is progressively explored.

Scanning with Moving Mirrors.

Several experimenters have worked with systems involving vibrating or revolving mirrors. One of the earliest of these systems was due to Szczepanik. With this device, the field of view is reflected on a mirror which is vibrated by an electromagnet, then reflected to a second mirror which is similarly vibrated at right angles to the motion of the first and, in turn, reflected to a light-sensitive device. Reception consisted of a similar system of electromagnets, the received impulse controlling the size of an aperture from a constant source of light. An oscillograph system, developed by Denes von Mihaly of Berlin, utilizing two oscillograph mirrors to accomplish exploration of the field of view, has been successfully demonstrated in Germany.

SCANNING THE FIELD OF VIEW

Slower speeds of scanning disc revolution are also attainable by including several series of spirals in a single disc, as shown in Fig. 19. Senabria, of Chicago, has incorporated this feature in his scanning disc, staggering the apertures in such a manner that only a part of the field of view is scanned by each series of spirals. Thus, with a 45-line disc, the first spiral scans lines 1, 4, 7, 10 and 13; the second, lines 2, 5, 8, 11 and 14; and the third, lines 3, 6, 9, 12 and 15. This distribution of picture elements through the whole field of view makes it impossible for the eye to become conscious of the scanning pattern, and tends to equalize the flicker throughout the reproduction.

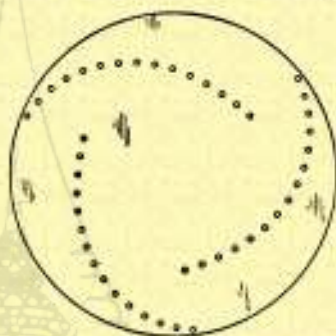

FIG. 19.—The staggered scanning disc with three 15-hole spirals produces three images per revolution, each consisting of a third of the subject.

Possibilities of Improvements in Scanning Systems.

This by no means concludes the catalogue of the various systems used for exploring the field of view. A considerable number of experimenters have worked out their own favorite scanning progressions, all of which accomplish the same thing in a different way. In the last analysis, the fundamental values of a scanning system are determined by the number of picture elements into which the field of view is resolved and the number of repetitions of the complete field made per second. Modification of the progressive

TELEVISION

order of sweeps from top to bottom to more complex patterns has not yet proved sufficiently advantageous to offer any important improvement.

There appear to be no insuperable difficulties to carrying on the process of scanning to almost any degree or number of picture elements which may be necessary to secure television of adequate quality. The available courses open to the designer are literally infinite in number. He may employ discs revolving in opposite directions or combinations of discs and

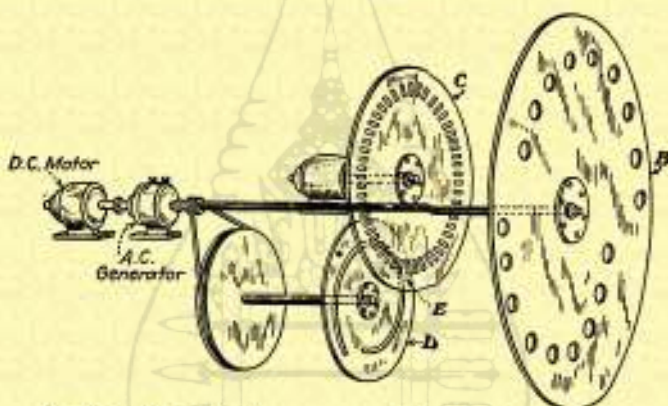

FIG. 20.—The triple-disc scanner used by Baird in his earlier demonstrations.

moving mirrors. The optical and mechanical problems involved in such methods, however, increase tremendously as greater detail is attempted. While delicate equipment is allowable at the pick-up point, where skilled personnel may be employed, the importance of simple and rugged equipment at the reproducing point is a major consideration if a large and scattered audience is to be served with home television.

SCANNING THE FIELD OF VIEW

Rating the Quality of Scanning Systems.

The human eye responds in a manner quite similar to the television pick-up apparatus. Two heavy black dots on a white card are distinguished as two separate dots when held close to the eye. As the card is moved away, a point is reached where they blend into one spot. The ability to distinguish two points as separate identities is determined by the resolving power of the eye. At the distance just short of the point that the two spots blend into one, the angle formed by two lines drawn from the extremities of the spot to the retina of the eye is known as the resolving angle of the eye.

The capacity of a television pick-up system for detail can be rated according to its resolving angle. All the detail within the resolving angle is blended and lost. If the resolving power of the television pick-up is less than that of the eye, blurring of detail becomes noticeable. The ratio of the resolving angle of the eye to the resolving angle of the television pick-up is a measure of the attainable fidelity of the system.

As with any artificial system of reproduction, the television system involves a substantial sacrifice from perfect realism. For example, the average human ear responds to from 20 to 20,000 vibrations per second. A radio receiver of admirable faithfulness of reproduction may reproduce from 50 to 5,000 vibrations accurately, or approximately 25 per cent of the range of the ear. The frequencies above 10,000 are not essential to pleasing reproduction or to satisfactory entertainment service. In the same way, the entire response capacity of the human eye need not be duplicated for satisfactory visual reproduction.

We have not had sufficient experience with television to determine what percentage of completely accurate reproduction is necessary to constitute an acceptable television service. It is of interest, however, to evaluate some of the present systems. Consider the case of a pick-up system focused on the head of a single person which resolves the subject into 2,304 picture elements by means of a 48-hole scanning disc. If we assume that the subject is 3 feet from the photoelectric cell and the field of view is 2 feet square, the picture-element area has one forty-eighth of the width of the field or $\frac{1}{2}$ inch. The resolving angle of such a scanning system is one whose tangent is $\frac{1}{72}$ or approximately 48 minutes. This is roughly 48 times as large a resolving angle as that of the eye. In other words, the resolving power of such a television pick-up system is about 2 per cent of that of the eye.

Scanning of Motion Pictures.

When we attempt to televise or scan the field of view of a normally illuminated scene, particularly an outdoor subject, we deal with extremely small units of light energy and, consequently, extremely small outputs from the photoelectric cell. This limitation can be overcome by the use of photography. A motion-picture camera secures about twenty complete reproductions of the field of view in a convenient form, each consisting of perhaps millions of picture elements, vastly in excess of the number which we can successfully transmit over wire or radio channels. By focusing an exploring beam which oscillates from side to side through the film which is being reeled slowly before it, we secure substantial variations of

SCANNING THE FIELD OF VIEW

light intensity to actuate the light-sensitive system. These variations may be somewhat greater than those required for making the film in the first place. The film is, in effect, a light amplifier because the light



FIG. 21.—Dr. C. Francis Jenkins and his motion-picture lens scanning device.

variations secured by scanning the film with a moving light beam projected through it are greater than the light required to record the scene directly from the field of view. The reproduction embodied in the motion-picture film is of such texture as to constitute an ideal method of reducing the field of view to a form

well adapted to the limitations of the available scanning and light-sensitive systems. The only substantial sacrifice is in connection with spot news events which cannot be resolved into motion-picture form without an appreciable loss of time.

The scanning of motion-picture film requires only horizontal scanning, the vertical element being contributed by reeling the motion picture before a light source oscillating from side to side. For example, if each frame of the motion picture is to be divided into 100 lines, the light source must oscillate from side to side 100 times while the film moves the distance of one frame.

Many students of television believe that the first transmissions for general public service will be confined to close-ups of individuals and the television of motion pictures because of technical limitations. This is no dismal prospect, considering the rapidity with which motion-picture news services reduce the events of the day to motion-picture film. The amount of illumination offered the light-sensitive element when motion pictures are used as the subject of a transmission depends on the brilliancy of the local source used and is therefore independent of the average brilliancy of the original scene. We have, therefore, in the film, a tool of tremendous importance in overcoming some of the difficulties occasioned by direct television of comprehensive and long-range scenes.

Television Compared with Motion Pictures.

There has been a tendency to compare television reproduction with motion-picture projection without taking into consideration certain important differences tending to invalidate the comparison.

SCANNING THE FIELD OF VIEW

With motion pictures, every picture element of each field of view is exposed upon the screen for $\frac{1}{48}$ second. It is estimated that 10,000,000 separate chemical actions, each controlled by the shading of the original field of view, contribute to the make-up of each frame. Persistence of vision carries over these 10,000,000 picture elements distributed by projection on the screen for the $\frac{1}{48}$ second interval during which the shutter interrupts projection so that the next frame may arrive at its correct position after that interval. These numerous picture elements are again projected with whatever changes are imposed by the motion of the subjects during the interval. The eye is thus supplied with 10,000,000 new picture elements each $\frac{1}{24}$ second, each persisting before it for $\frac{1}{48}$ second; that is 240,000,000 picture elements each projected for $\frac{1}{48}$ second per second.

An imaginary television system, presenting 10,000,000 picture elements per field of view, with the field repeated 24 times per second, offers decidedly less information to the eye than the equivalent motion picture. With conventional television, only a single picture element is projected at a time. The greater the number of picture elements, the less time each is offered the eye. With existing television systems each individual picture element is illuminated singly for an interval equal to the total time required for the reproduction of the complete field of view divided by the number of picture elements constituting it. Accordingly, with the imaginary television system described, each picture element is illuminated but $1/240,000,000$ second as compared with $\frac{1}{48}$ second in the case of the motion picture.

TELEVISION

With television, there is no interruption of the process of presenting picture elements, although in motion-picture reproduction they are presented but half of the total time. This fact has been stressed by television enthusiasts as a great advantage. As a matter of fact, there is no advantage to be gained by shortening the "blank" interval in motion-picture presentation to less than $\frac{1}{48}$ second, because it imposes no hardship on the eye. On the other hand, the series procession of picture elements of present-day television has the very serious disadvantage of reducing the total illumination as the number of picture elements increases. It appears, then, that with the light source of equal intensity, television of motion-picture detail offers to the eye only a five millionth of the light value of a motion-picture reproduction. With so short a period of illumination as $\frac{1}{240,000,000}$ second per picture element, there is no known light source sufficiently brilliant to make an impression which will carry over through persistence of vision for $\frac{1}{24}$ second.

We have considered only one problem in this comparison, the brevity of the time available for illuminating each picture element in reproducing television of motion-picture quality. As a matter of fact, an equal hardship is imposed on every element of the television system, from scanning to reproduction. Obviously, with present methods, we are forced to deal with a very much smaller number of picture elements than 10,000,000 per frame. The most ambitious television device which has been demonstrated up to this time presents 72 lines, or approximately 5,000 picture elements per frame. Even with such a crude system,

SCANNING THE FIELD OF VIEW

assuming 20 reproductions of the scene each second, each picture element is illuminated only about $1/100,000$ second per frame as compared with $1/48$ second with the motion picture. The results of the best laboratory television and ordinary motion pictures are still very far apart.

Of course, the problems of television are not nearly so hopeless as this extreme comparison would indicate. Prospective developments in reproduction methods present a somewhat more hopeful view. For example, the illumination of each picture element at the reproducer may be made to continue for considerable periods beyond the time that the transmitted impulse controls it by utilization of a fluorescent screen. But television systems which do not depart from the conventional method of presenting but one picture element at a time, when projected to motion-picture quality, are nevertheless subject to the extraordinary problems herein indicated.

The presentation of picture elements in a continued series, even with sufficient repetition to eliminate flicker, imposes great burdens on the eye. Were an average person compelled to watch a television reproduction, even one of as few elements as 2,304 (48-line television) for a period of 2 hours, the eye fatigue would probably be sufficient to cause considerable discomfort. On the other hand, watching a motion picture for 2 hours causes only moderate eye fatigue. This is but one of the many problems of television which indicate that a great deal remains to be overcome before television becomes the equivalent of the motion picture. Fortunately, we need not await the approach of this high standard before television renders a useful and widespread service.

CHAPTER V

THE LIGHT-SENSITIVE ELEMENT

The function of the light-sensitive element in television transmission is to set up current variations proportionate to the light reflected upon it from the field of view as it is disintegrated by the scanning system. The function of the light-sensitive system is, therefore, analogous to that of the microphone in the broadcasting of sound. The light-sensitive element is frequently termed the "electric eye." The rods and cones of the eye perform an identical function in a multiple fashion in the human nervous system, transforming the light energy reflected to the eye from the field of view into impulses suited for transmission through the nerve system to the brain. The rods and cones of the eye are, in fact, light-sensitive units and the nervous system is analogous to, if not actually, a network of electrical communication circuits.

Any substance which changes its electrical characteristics as a result of the influence of light is said to exhibit photoelectric properties. Some substances, such as selenium stibnite and cuprous oxide, change their resistance in response to light. The alkaline metals, such as zinc, potassium, caesium and rubidium, on the other hand, release electrons in response to light. It is interesting that Heinrich Hertz, who laid the foundations for radio communication by his funda-

THE LIGHT-SENSITIVE ELEMENT

mental experiments with electric-wave phenomena, was the first to observe the influence of light on an oscillating spark discharge. Emission of electrons is facilitated by enclosing the light-sensitive material in a high vacuum.

Requirements of Light-sensitive Elements in Television.

The photoelectric phenomenon utilized for the light-sensitive element in a television system must operate with a speed so great that an adequate number of picture elements may be presented to it in extremely rapid succession without sacrificing the accuracy of the response. Its response must be linear or at least proportionate to the wide variation of light intensities which may be encountered in an average field of view. It should respond to equal light stimuli throughout the color scale in a manner somewhat similar to the response of the eye if natural subjects are to be the subject matter of transmission. Stability of operation, mechanical ruggedness and uniformity are characteristics which will be increasingly important as light-sensitive devices are more extensively used.

Properties of Selenium.

Selenium was the first of the light-sensitive substances to be the subject of extensive experimental work in picture transmission and television. If selenium is annealed at about 200° C. it becomes a conductor, the resistance of which varies as the square root of the light impressed upon it. In its usual form, selenium is deposited in a very thin coating on a non-hygroscopic insulating material with two electrodes forming the terminals. The Giltay cell is a

well-known form of selenium cell. Two spirals of platinum wire, 6 millimeters apart, are wound upon a rectangular piece of steatite, about 3 by 6 centimeters in dimensions. The platinum wires form the terminals. The thinner the layer of selenium, the

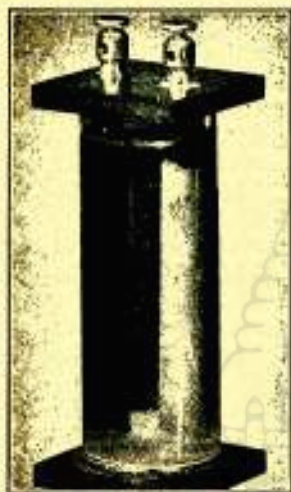

FIG. 22.—A photovoltaic cell developed by S. Wein notable for its large output and rugged qualities. (Courtesy of Radiovision Corporation.)

higher the resistance and also the more sensitive the cell. A well-made Giltay cell of these dimensions has a resistance of about 250,000 ohms.

Selenium has the disadvantage of being more sensitive at low frequencies or the red end of the color scale; but its outstanding shortcoming is the fact that resistance changes due to a light stimulus tend to continue for an interval after the light stimulus is removed. The heavier the deposit, the greater the lag effect. Although selenium, for these and other reasons, has been largely abandoned for televi-

sion purposes in favor of the photoelectric tube, great improvement in the performance of selenium is not an unreasonable expectation. Korn, in his picture-transmission system, tends to overcome the lagging effect of selenium by utilizing two cells on the opposite sides of a Wheatstone bridge with the result that the lag of one cell is counter-balanced by that of the other. T. Thorne Baker has suggested the possibility of utilizing a high-frequency alternating current to overcome the lagging

THE LIGHT-SENSITIVE ELEMENT

tendency of the cell. J. L. Baird, the famous Scotch television experimenter, has utilized the selenium cell in some of his earlier television transmitters.

Another photoelectric phenomenon, the responsiveness of cuprous oxide, first observed by Pfund, has recently been utilized by S. Wein in making a liquid light-sensitive element. A cuprous oxide electrode and a collecting electrode are sealed in a glass tube immersed in an electrolyte. This is termed by Wein a photovoltaic cell and has been successfully used in reproducing talking motion pictures. It is inexpensive to manufacture and uniform in its characteristics, two qualities not yet fully attained by other forms of light-sensitive cells.

The Photoelectric Tube.

For the exacting requirements of television service, the photoelectric tube or cell is used almost exclusively. It depends for its action on the quality possessed by some of the alkali metals of emitting negative electrons in a vacuum as a result of a light stimulus. The form of modern photoelectric tubes is due to the pioneer experiments of Elster and Geitel in 1889. It has been found that the alkali metals are photoelectrically sensitive to a range of light frequencies according to their electropositiveness as shown in the periodic table of the elements. Sodium, for example, in its pure state, is not photoelectrically sensitive for wavelengths longer than 0.58 microns. The micron μ is equal to 10^{-6} meters; the Ångström unit (Å.U.) to 10^{-10} meters. Potassium responds to longer waves, rubidium to still longer, and caesium to the longest visible light waves bordering on the infra red.

TELEVISION

WAVELENGTHS OF VARIOUS RADIATIONS

Kind of radiation	Ångström units	Centimeters
Gamma rays.....	0.02 to 1.37	0.000000002 to 0.000000137
X-rays.....	0.07 to 13.20	0.000000007 to 0.0000001320
Shortest ultra-violet.....	136	0.00000136
Transmitted by quartz or rock salt....	1,800	0.000018
Shortest solar waves that can pass through atmosphere.....	3,000	0.00003
Shortest waves transmitted by glass....	3,300	0.000033
Shortest visible waves.....	3,700	0.000037
Violet.....	4,000	0.00004
Blue.....	4,600	0.000046
Green.....	5,200	0.000052
Yellow.....	5,700	0.000057
Orange.....	6,000	0.00006
Red.....	6,600	0.000066
Red (longest visible waves).....	7,700	0.000077
Limit of solar spectrum.....	53,000	0.00053
Longest heat radiation.....	4,200,000	0.042
Shortest Hertz waves:		
Harmonic overtone.....	2,200,000	0.022
Harmonic with tuned receiver.....	4,000,000	0.040
Fundamental.....	9,000,000	0.090
Hertz waves in practical wireless tele- graphy (recently lowered to 3 m.)...	3 to 20,000	meters

(From "Physics for Technical Students," by Anderson. The McGraw-Hill Book Company, Inc.)

A typical commercial photoelectric cell is shown in Fig. 23. A deposit of silver is distilled upon the inside of a spherical glass bulb. Upon this a photoelectric metal, usually potassium or caesium, is deposited, the silver forming the contacting element for

THE LIGHT-SENSITIVE ELEMENT

the cathode connection, usually terminating in a pin similar to those of the conventional vacuum tube.

The anode is in the form of a wire ring or ribbon which is carefully insulated from the cathode. Because of the great amplification to which the output of photoelectric cells is usually subjected, special precautions are necessary to prevent the slightest leakage between anode and cathode, which would manifest itself as distortion in the reproduction. A window to admit light rays is formed by applying heat with a torch after the active coating has been distilled. This drives off a part of the silver coating. Frequently a small quantity of hydrogen is injected into the tube at the conclusion of the distilling process to form potassium hydride, which responds more uniformly through the scale of light frequencies than potassium.



FIG. 23—A conventional photoelectric cell suitable for television and industrial purposes.

Rarified Gas Photoelectric Tubes.

As with the familiar vacuum tube, much greater output can be secured from photoelectric tubes by diluting the vacuum with a small quantity of inert gas to a value in the order of a few tenths of a millimeter of mercury. Photoelectric emission is then effectively assisted by ionization. The density of the gas and the voltage applied to the cell must, however, be carefully adjusted to avoid unstable operation.

The more rapidly the cell must respond, as determined by the number of picture elements scanned per second, the smaller the reliance which can be placed on the ionization phenomenon. While gas cells are satis-



FIG. 24.—A small Westinghouse photo-cell used extensively for industrial purposes.

factory for use with systems involving picture-signal frequencies of fifty thousand or so, it is probable that they will prove too erratic and unstable for considerably higher response frequencies, apparently necessary in high-quality commercial television service.

Figure 25 shows the spectral response characteristics of the gas and vacuum types of light-sensitive tubes made by the Westinghouse Company. The VB cell is most responsive at the violet and the red ends of the visible spectrum but relatively unresponsive at the center, where vision is most active. The VA cell, on the other hand, more nearly approaches the range of the eye, but is only one-fifteenth as sensitive as the VB type.

Characteristics of Photoelectric Tubes.

As we might expect, the photoelectric tube exhibits characteristics similar to those of the familiar vacuum tube. As the voltage supplied to the anode is increased, the response for a given illumination increases. There is a definite saturation for a given illumination intensity with a fixed voltage, and that saturation varies according to the light frequency or

THE LIGHT-SENSITIVE ELEMENT

color of the illumination impressed upon it. In general, commercial photoelectric tubes do not possess the same response characteristics to different light frequencies as does the eye. This characteristic makes necessary the grotesque make-up used by subjects of television transmissions.

Now that extensive commercial uses are developing for photoelectric tubes, their variable response through the color range will undoubtedly be remedied, and

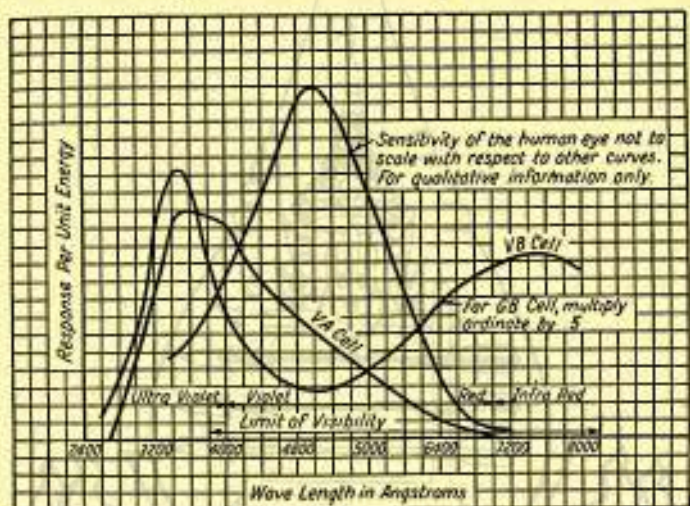

FIG. 25.—Color sensitivity of average Westinghouse VA and VB cells.

manufacturers will soon be advertising "straight-line frequency" light-sensitive cells. It is already possible to produce photoelectric cells, for laboratory purposes, exhibiting almost any desired color response characteristics.

For purposes of color television, the Bell Telephone Laboratories, under the supervision of Dr. H. E. Ives,

TELEVISION

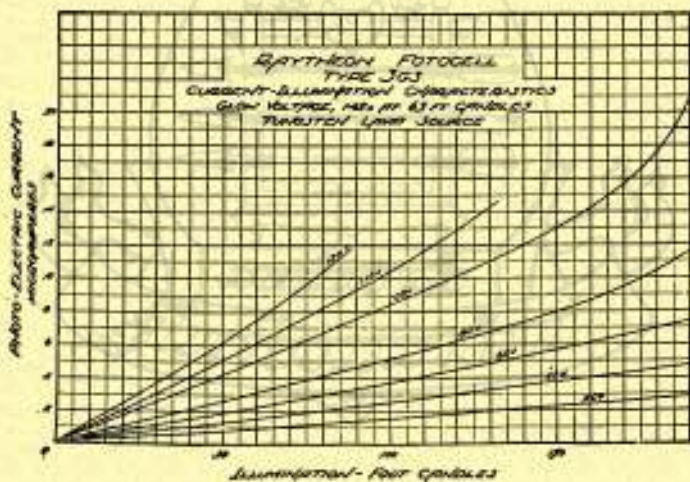
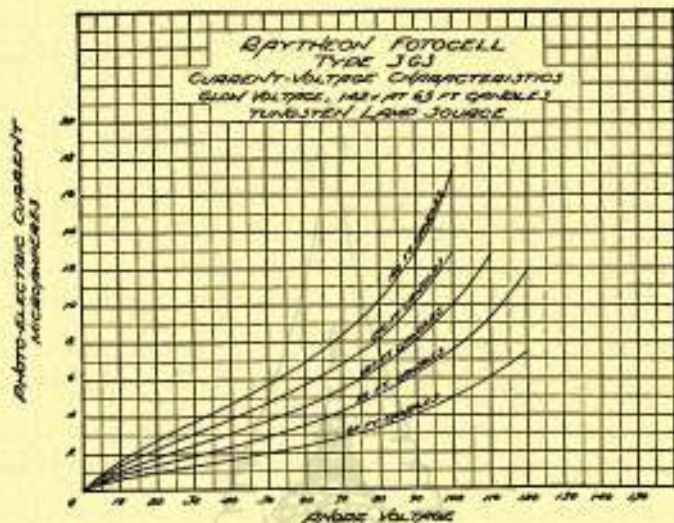

Fig. 26.—Characteristics of Raytheon 3G3 photoelectric cell.

THE LIGHT-SENSITIVE ELEMENT

have developed a special photoelectric tube, sensitive throughout the entire visible spectrum. The cathode

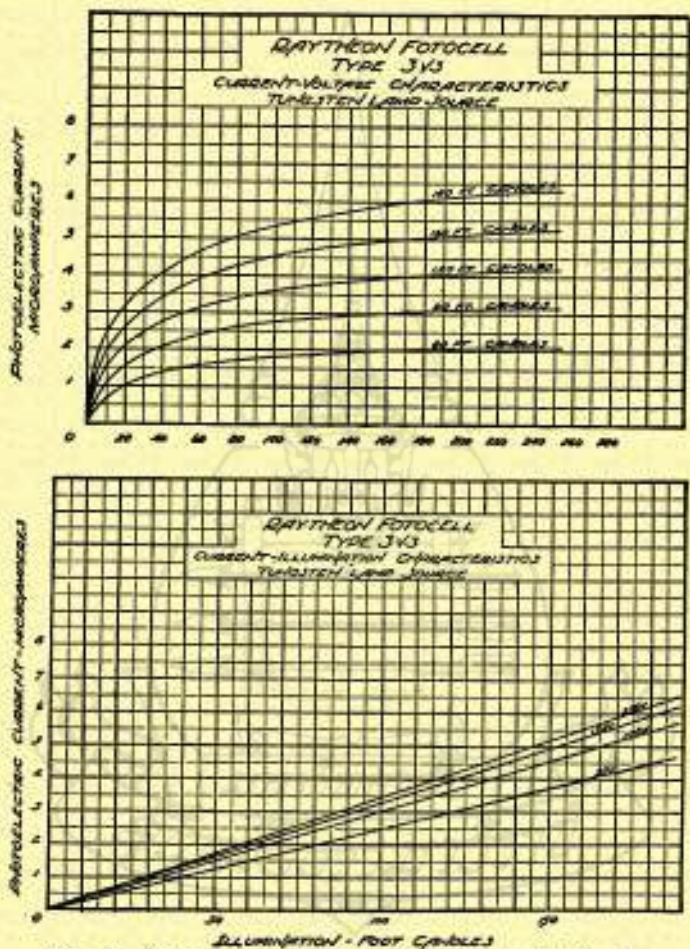

FIG. 27.—Characteristics of Raytheon 3VS photoelectric cell.

is of sodium, sensitized by a complex process, utilizing sulphur vapor and oxygen. Mention has already been

TELEVISION

made (page 39) of the cells built in the same laboratories to be particularly responsive to blue light of a frequency least annoying to the eye, so that a human subject can be scanned by a blue scanning light at the same time that he is observing a television reproduction in two-way television. This cell used a potassium cathode sensitized with sulphur. The delicate technique of photoelectric cell construction will undoubtedly keep pace with other developments in the art.

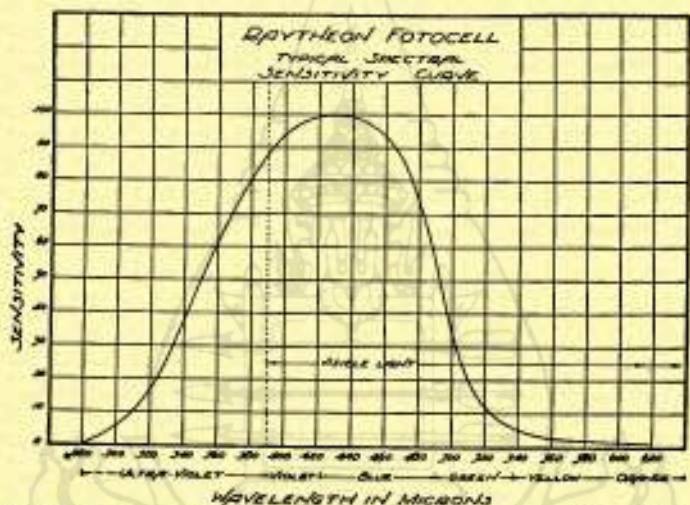

FIG. 28.—Spectral response curve of a typical Raytheon photoelectric cell.

Qualities of Photoelectric Cells.

The most important feature of a properly made high-vacuum photoelectric tube, as it concerns the problems of television, is that its response is instantaneous. Therefore, we can present it successive picture elements at a high rate and secure a response proportion-

THE LIGHT-SENSITIVE ELEMENT

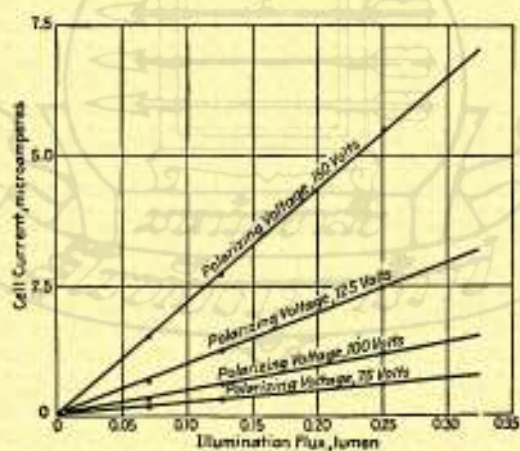
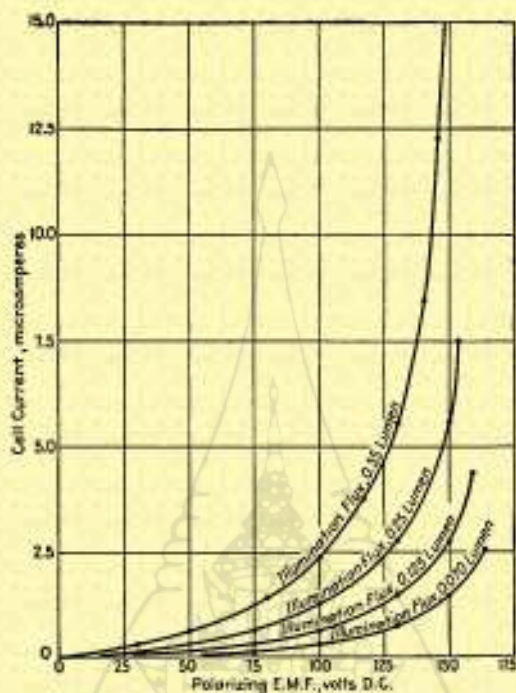

FIG. 29.—Characteristics of Jenkins SRI-16 photoelectric cell.

TELEVISION

ate to the light changes impressed upon it. The photoelectric cell is, moreover, exceedingly sensitive. Ferrié, for example, describes a photo-cell amplifier method of measuring light from the stars in a paper describing his experiments at the National Observatory in Paris.¹ Using a photoelectric tube of the potassium hydride type, coupled to a single-stage vacuum amplifier using a tube with two grids, he secured a plate-current variation of five microamperes from the star Capella as a result of the light collected from it through an astronomical telescope.

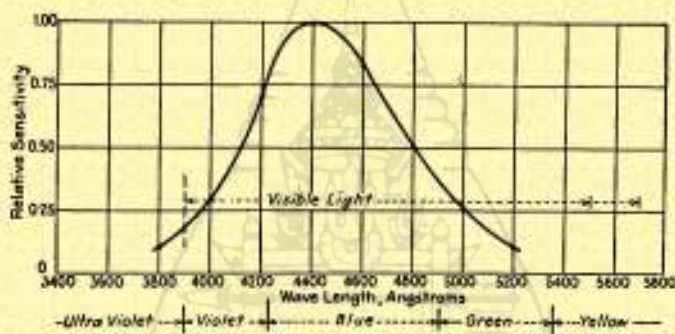

FIG. 30.—Spectral-response curve for a Jenkins photoelectric cell.

The principal shortcoming of the photoelectric tube is the exceedingly small output which can be obtained from it, although constant progress is being made in securing larger outputs for a given light stimulus. Nevertheless, tremendous amplification is invariably required, involving the usual difficulties inherent in such amplifiers.

¹ FERRIÉ, G., R. JOUAST and R. MESSY, Amplification of Weak Currents and Their Application to Photoelectric Cells, *Proceedings Institute of Radio Engineers*, Vol. XIII, No. 4, August, 1925.

THE LIGHT-SENSITIVE ELEMENT

The high impedance of photoelectric tubes requires a high-resistance coupling to the amplifier, introducing random voltages in its output. It was the discovery of random voltages in such coupling resistors, observed when the enormous amplification necessary was used in the Bell Laboratories television experiments, which led to the substitution of the selective illumination system for the selective observation system first used.¹

Stimulated by the commercial requirements of talking motion pictures, constant progress is being made in the development of the photoelectric cell. Undoubtedly, its frequency or color characteristic will be improved; the difficulty of producing uniform photoelectric tubes will be remedied; and larger outputs will be available, long before some of the more pressing problems of television are solved. The burden now placed upon the amplification systems associated with television systems will be materially lessened with a consequent reduction of the distortion and blemishes now experienced, for which the vacuum tube is responsible.

Coupling the Photoelectric Cell with Amplifier Systems.

The photoelectric tube, as used in television work, is usually coupled directly to the grid of the first amplifier tube. Figure 31 shows a circuit utilizing a common plate potential source for the first amplifier stage and the photoelectric tube. Figure 32 shows a two-stage resistance amplifier coupled with a photoelectric cell. A separate battery is used to furnish the polarizing potential to the photoelectric tube. The voltage drop across resistance R_1 is coupled through

¹ See pages 32 and 38.

TELEVISION

capacity C_1 to the grid of the first vacuum-tube stage. In utilizing a circuit of this type for television purposes, care should be taken that the resistance R_1

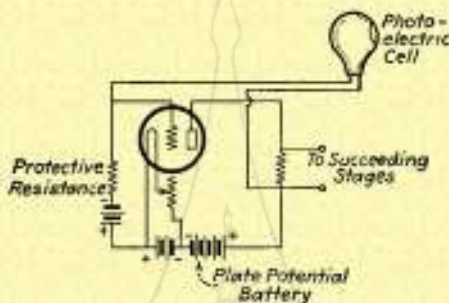

FIG. 31.—Photoelectric cell circuit using common plate potential battery for amplifier and photoelectric cell.

is not so large as to cause loss of higher frequencies through the capacitive reactance of the photoelectric

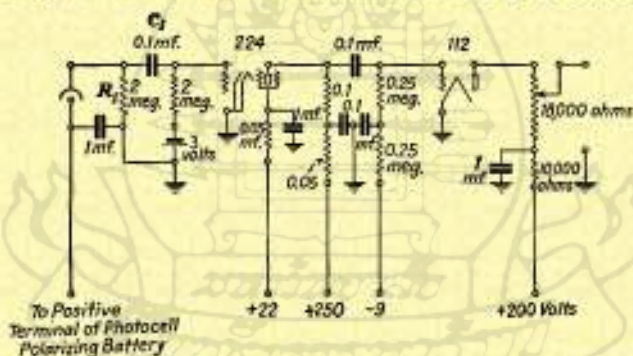

FIG. 32.—Photoelectric cell with associated two-stage resistance coupled amplifier.

tube or to affect the polarizing voltage itself. The coupling capacity C_1 together with the input capacity of the tube should not be sufficiently large to cause the

THE LIGHT-SENSITIVE ELEMENT

possibility of appreciable losses by reason of its capacity to ground. Exceedingly short leads must be used and every precaution observed to prevent losses and the introduction of disturbances in the early stages of the photoelectric cell amplifiers.

Photoelectric Tubes in Television Service.

The task imposed upon the light-sensitive elements of a television system of commercial quality is exceedingly great. As we increase the number of picture elements presented to the light-sensitive device, we proportionately reduce the length of time during which each element is subjected to the observation of the light-sensitive element.¹ To secure accurate response, the light-sensitive element should be capable of causing a current fluctuation in its output circuit corresponding to a change from full white to full black or *vice versa* from one picture element to the next and, furthermore, for such responsiveness to be of value in the final reproduction, the transmitting amplifier system, the transmission medium, the reproduction amplification system and the unit converting the electrical impulse to light must also be capable of faithfully carrying out the response of the photoelectric cell to so rapid a change. Furthermore, as we increase the number of picture elements we, must, to gain the full reward of that improvement, be certain that the photoelectric tubes respond with full accuracy to finer discriminations of shading. Otherwise, the additional breaking down of the field of view into more picture elements is not restored in the reproduction and no material gain is accomplished.

¹ See page 53.

TELEVISION

Perhaps the greatest burden imposed upon the light-sensitive element in television of commercial quality is occasioned in the televising of outdoor scenes. The reason why experimental television devices have been limited in their scope to the viewing of close-ups of individuals is the tremendous increase in total number of picture elements per reproduction made necessary for a clear reproduction of an extensive field of view. The fact that many people prefer to take field glasses to a football game is an indication that even greater resolving power than is possessed by the eye is desirable in a television system designed to pick up such events.

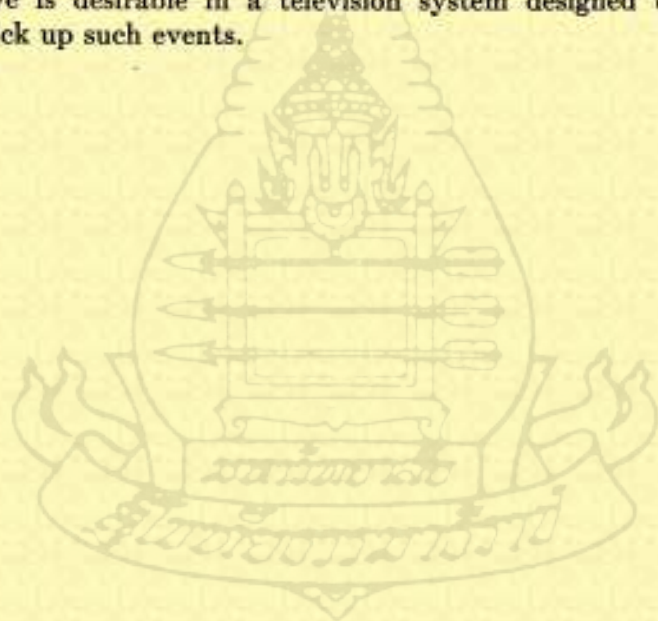

CHAPTER VI

TRANSMISSION OF TELEVISION SIGNALS

The light impulses constituting the field of view having been reduced to electrical impulses as a result of disintegration by the scanning system and the functioning of the photoelectric cell, the transmission of the resultant picture signal through space becomes a problem of communication engineering. For the purpose, established communication methods and instruments are employed, suitably modified to meet the special requirements imposed by the television signal. The first demonstrations of television made use of low-frequency amplifiers embodied in radio transmitters and receivers designed for broadcasting of speech and music. Such communication facilities have sufficient capacity for demonstrating the principles of television on a limited scale.

It is beyond the scope of this book to deal with problems of communication. The design and construction of amplifiers, radio transmitters and receiving systems are the subject of an extensive technical literature. The special requirements which television transmission imposes upon communication facilities are, however, vital considerations, and the meeting of these requirements constitutes one of the major development problems to be solved before regular television service is a reality.

Limitations of Broadcast Receivers.

The highest rate of electrical communication involving a band of frequencies which must be interpreted according to both frequency and intensity is encountered in high-quality broadcasting of speech and music. An average broadcast transmitter and receiver respond faithfully to a band of audio frequencies extending from 100 to 5,000 cycles, or a total band width of 4,900 cycles. Assuming 18 repetitions of the field of view per second, a transmitter with a maximum band capacity of 4,900 cycles could radiate a picture signal comprising 544 picture elements, or a square field of 23 lines. If a broadcast transmitter of unusually good quality, handling up to 8,000 cycles, were used for the transmission of a television picture signal, the field of view could be broken down into 889 picture elements, or 30 lines.

Quite obviously, the entertainment value of a television reproduction of 23 or 30 lines is so meager that we may conclude that neither broadcast transmitter nor receiver is capable of rendering any general television service. So long as we rely upon progressive and repeated scanning, a special communication system, involving much broader bands than those required for speech and music, is essential to television, and both transmission and receiving apparatus of special design must be utilized.

Whenever a new discovery in television is announced, or a publicity stunt successfully carried out, radio dealers report that prospective buyers of broadcast receivers hesitate because they fear that practical television will soon make existing receivers obsolete. But, unless television develops on radically new prin-

ciples, accomplishing its service with a much lower rate of signaling than is now essential, the present radio-broadcasting system, from transmitter, through ether channel, to receiver, is about as useful for television as a small boy on roller skates for pulling a freight train.

Transmission Band Required for Television.

The theoretical maximum frequency encountered in a television picture signal produced by progressive and continuous scanning can be ascertained by calculating the frequency band necessary for transmitting a checkerboard pattern, each square of which has the dimensions of a picture element. The output of the photoelectric cell in that case rises from minimum to maximum in scanning a black square, and then falls from maximum to minimum to complete the scanning of the next succeeding white square. This pulse repeated continuously for each pair of picture elements produces a simple pulsating picture signal of a frequency equal to half the number of picture elements scanned per second. Any variation in the checkerboard pattern decreases the frequency, and no variation of the pattern tends to increase the frequency. The theoretical maximum frequency (without taking into consideration the possibilities of harmonics and their resulting influence in making possible accurate reproduction of the signal) can therefore be determined by the following formula:

$$f_{max} = \frac{p \times r}{2}$$

where f_{max} equals the highest frequency present in the picture signal, p the number of picture elements into

which the field of view is resolved and r the number of repetitions of the entire process per second.

Capacity of 100-kilocycle Channels.

The 100-kilocycle channels now being used for experimental television are therefore capable of accommodating a television transmission of 10,000 picture elements with 20 repetitions per second, or of 12,500 picture elements at 16 repetitions. These are equivalent to square fields of 100 and 112 lines, respectively.

The nearest approach to television of this detail so far made was accomplished by the Bell Telephone Laboratories in the two-way wire television demonstration of June, 1930.¹ A rectangular field was scanned to 72 lines at 18 repetitions, with a maximum frequency of 40,000 cycles. The amplifiers and wire channels used handled a band of from 10 to 40,000 cycles. It is not yet practicable to transmit such broad bands of signal reliably over any known electrical communication channel, other than very short wire circuits especially treated to handle them.

What the Maximum Picture Signal Frequency Contributes.

Some television experimenters have claimed that the amplifier systems and the communication channels used for television do not have to handle nearly so broad a band of signals as theoretical considerations indicate. If the theoretical maximum rate of change is not actually encountered in practice, that fact is of the utmost importance because the paucity of communication channels available for television purposes

¹ See also pages 30-41, 101, 104-106, 155-157.

TRANSMISSION OF TELEVISION SIGNALS

and the difficulty of greatly increasing the band width handled by amplifiers will inevitably impede commercial progress, unless methods much more economical of communication facilities are evolved.

In describing the 50-line television system demonstrated by the Bell Laboratories several years previous,¹ its designers state that the theoretical maximum frequency of 22,125 cycles was not actually utilized. By inserting filters and gradually decreasing the high-frequency cut-off, serious loss of detail was not observed until the maximum frequency transmitted was down to 15,000 cycles. However, the 72-line system of 1930,² with its greater detail, required a communication system capable of handling the theoretical maximum frequency to secure the highest quality of reproduction of which the process is capable. In short, when fine scanning is employed so that real detail is embodied in the picture signal, any failure of the transmission and reproduction system to handle the highest frequency required nullifies the advantages gained by fine scanning. In those cases where communication facilities with a maximum capacity of less than the theoretical maximum frequency in the picture signal have appeared to be satisfactory, it has been due, very probably, to deficiencies in the optical and amplifier systems which themselves reduce the detail attainable in reproduction below the standard merited by the scanning system.

¹ See also pages 38-39, 98-99, 111-112, 153-155. A series of papers describing the apparatus used in this demonstration appeared in the *Bell System Technical Journal*, Vol. IV, No. 4, October, 1927.

² See also pages 39-41, 101, 104-106, 155-157. Several papers describing the apparatus demonstrated on this occasion appeared in the *Bell System Technical Journal*, Vol. IX, No. 3, July, 1930.

TELEVISION

From the checkerboard pattern illustration, it is clear that the highest frequencies in the picture signal contribute the abrupt changes of intensity in the scanned line. A sharp alteration from black to white or white to black is embodied in the picture signal only as sharply as the frequency characteristic of the television communication system will permit. In practically every field of view, such sharp contrasts exist. They are embodied in the picture signal, and consequently in the reproduction, as a gradual rise in intensity, spread over the distance scanned in the time required to cover half a cycle of the maximum frequency handled by the system. The lower that maximum frequency, the less sharply are the rapid changes in contrast accommodated. The amount of fine detail embodied in the picture signal therefore depends upon the maximum-frequency capacity of the television system. Any lowering of the maximum-frequency capacity is reflected in loss of the finer detail and blurring of the sharper contrasts in the reproduction. When the fine dark lines and bright spots are blended with the background in a television reproduction, making it appear out of focus, it is an indication either of coarse scanning or of fine scanning transmitted through a communication system incapable of handling a sufficiently wide band of frequencies.

Maximum Frequency Required for Close-up Views.

Utilizing the familiar methods, the equipment at both terminals tends to exceed all economic limitations when anything over ten thousand picture elements is considered. Nevertheless, considerable entertainment service is offered by a system with

this limitation, provided that the observer secures a really accurate reproduction and portrayal of the face and of its expression. To accomplish such reproduction requires scanning and reproduction of very minute areas, in other words, a high density of picture elements. An expression of surprise, for example, created by a slightly increased opening of the eye and a small parting of the lips, means, in terms of television, alteration of the shading of very small areas corresponding to as little as a twenty-thousandth of the whole field of view. If such details are blended by rough scanning, the owner of a television reproducer will soon tire of watching the two or three faces performing before him.

In a close-up of the face occupying the entire field of view, a heavy pair of bow-rim spectacles may be but one-fiftieth of the width of the head, the part of the hair one one-hundredth, and wrinkles about the eyes and mouth one five-hundredth. To be portrayed in the reproduction, the area embodied in a picture element must be smaller than any item to be reproduced. Apparently the full capacity of 100-kilocycle channels is required for adequate portrayal of one or two faces in sufficient detail to possess sustained entertainment value.

The Ideal Subject for Television.

Many demonstrations of television have been offered with a considerably smaller number of picture elements than is suggested as the minimum for a limited entertainment service. No such demonstration is considered complete without the reproduction of a person smoking a cigarette. The cloud of

smoke is realistically portrayed because it is a simple area of white of indefinite size and shape. White space of such outline against an obscured background is the ideal subject for television purposes. It involves no sharp lines, and the main element is



FIG. 33.—Scanning a subject of this kind produces a single pulse per line for approximately one-third of each frame.

characterized in the picture signal merely by absence of modulation. The very failure of such a system to handle fine detail is an advantage with this particular subject, because it heightens the nebulous haze which makes it realistic. The attainable detail for entertainment service can hardly be judged by such an unexacting subject.

Low-frequency Requirements.

As important, though less difficult from the standpoint of channel requirements, is faithful reproduction of low frequencies in the picture signal. Low frequencies are as essential in the reproduction of simple shadowgraph subjects as in the most complex field of view. With horizontal scanning, the television signal required to transmit an image of a man standing before a white background in a dark overcoat is, for a major part of the transmission, as low as the picture repetition frequency itself. There is only one important change of tone from the plain white background to the black overcoat, producing only one change in signal intensity for each scanning line. Failure

TRANSMISSION OF TELEVISION SIGNALS

to respond to the lower frequencies tends to blend the man's figure with the background, a result which would make the whole procedure of transmission rather futile.

Appraising the Channel Requirements of More Complex Subjects.

It is unfortunate that any substantial improvement in television detail approaching commercial standards seems to involve increasing the signal frequency requirements somewhat beyond the capacity of existing amplifier systems and of available communication channels. In appraising the significance of improvements in television terminal apparatus, the added burden which they impose on communication channels must always be taken into consideration.

The light reflected to the light-sensitive system is, at all times, the average reflection admitted at each instant through the scanning aperture or illuminated by the exploring ray, regardless of the detail or sharp lines within the scanned area. A vertical line such as a wall, bar or post, in the field of view which occupies less than the width of the scanning area or picture element, blends with as much of the background as is scanned with it. If we move closer to the field of view with our television scanning apparatus, the dimensions of the important elements of detail become larger, but the scope of the field is proportionately reduced.

Suppose we consider the subject presented for the delectation of the television audience to be the highly elevating and entertaining spectacle of a clown on a bicycle indulging in a head-on collision with a tele-

TELEVISION

graph pole. In order to observe the clown riding in blissful ignorance toward the pole, the resulting collision and the graceful spill which is to ensue, the field of view scanned should be about 15 feet wide and 10 feet high. We will eliminate the element of varying distance of the subject matter from the photoelectric eye and consider the scene as a plane surface 10 by 15 feet. Because of the rapid motion involved, the repetition rate is to be 20 per second. By utilizing the maximum capacity of an experimental television band 100 kilocycles wide, the field may be broken down into 10,000 picture elements. The area of the field of view being 21,600 square inches, each picture element is 2.16 square inches or roughly, a square with 1.47 inches to a side. Because the scene is rectangular, we cannot scan it to 100 lines as that would give us 150 picture elements per line or a total of 15,000 for each reproduction. By scanning 82 horizontal lines of 122 picture elements each, we make maximum utilization of the channel, the product of these two figures giving approximately 10,000 picture elements. The scanning spot will therefore travel 82 times across the scene each twentieth of a second. The scene being 180 inches wide, the scanning spot will cover the distance of 180 by 82 inches, or 14,762 inches, each twentieth of a second, or 295,000 inches per second. Each hundred thousandth of a second, the distance covered by the scanning path is about 2.95 inches, or the width of two picture elements.

Because of the limitations of our channel, the most information which we can convey through the television system in a single cycle is a change from white

to black to white or the reverse, each having the width of a picture element. In other words, a series of white and black stripes, 1.5 inches wide, can be successfully reproduced. But a pattern of lines 0.75 inch in width would be blended inasmuch as they would be simultaneously scanned, and the resulting reproduction would be uniform medium gray. For the same reason, the frame of the bicycle, the sprocket, the handle bars, the details of the profile of the clown's face would be partially or wholly blended with the background. Maintaining this scene within a 100-kilocycle channel would confine response to details having a cross section 1.5 inches, excluding many elements contributing significantly to the realism of the scene.

Losses in Detail by Inadequate Transmission System.

Furthermore, if the amplifier system at the transmitter handles no more than eighty thousand cycles, the most rapid changes are not effectively radiated. The detail lost because of failure of the amplifier to reproduce the necessary frequency range is of an identical character with that caused by increasing the elemental area observed through the scanning system. Obviously no television system is any better than the amplifier and transmission qualities of the communication medium used in connection with it. No improvement in the scanning or pick-up system can be reflected in reproduction unless the transmitting amplifier, the transmitting channel, the receiving amplifier and the controlled light-reproducing system also respond to the increased rate of scanning. Conversely, improvement of the amplifier

TELEVISION

system to respond to higher frequencies than are analyzed by the scanning system contributes no improvement in the detail of reproduction.

Significance of Television Demonstrations Not Involving Radio Channel.

Demonstrations of television are frequently given to the press by inventors and by manufacturers of electrical and radio apparatus at radio shows and before societies. But unless such demonstrations involve the use of a radio channel between transmitter and reproducer, they merely show the capabilities of the terminal apparatus and not of television communication. Because it seems about as easy to transmit speech and music by radio as through wires, it is too readily assumed that a demonstration of wire television is clear proof of the possibilities of radio or long-distance wire transmission. A short-length wire channel is ideal from the transmission standpoint and successfully avoids some of the most baffling problems of television transmission. It is appreciation of the magnitude of the radio transmission problem which animates the prediction sometimes made by authorities in the field that television is more likely to be distributed over wire lines for reproduction in public places to which admission is paid.

The most important difference between wire and radio transmission of television arises out of the peculiarities of high-frequency channels with which the broadcast listener in general is not familiar. High-frequency channels must be used for television purposes because broad bands of signals are not available elsewhere for television.

TRANSMISSION OF TELEVISION SIGNALS

Selective Fading in Short-wave Transmission of Speech.

The two most important effects to be contended with are selective fading and radio echoes. Even with channels as narrow as 8 to 10 kilocycles, such as those used in transatlantic telephony, selective fading is readily observed, as indeed in almost any transmission of speech and music over long distances. For example, a transmitter utilizing a single 5,000 cycle band from 3,000,000 to 3,005,000 cycles may at one instant find the signal swinging lower in intensity from 3,000,000 to 3,100,000 cycles but rising at the same time from 3,004,900 to 3,005,000 cycles. Broadcast listeners, being entertained by programs coming from across the seas through a short-wave radio link, have observed that the low notes come booming in for a few moments while the higher frequencies are fading out almost entirely. In speech, this gives the speaker a muffled and indistinct tone, difficult to understand. A moment later, the high frequencies are likely to rise, giving clear articulation but total absence of body. Many technical papers have been published describing some of these baffling effects.¹

Selective Fading on the Transatlantic Circuit.

Measurements made by the Bell System of the varying transmission characteristics of the short-wave transoceanic radio circuit between England and the United States indicate that selective fading

¹ POTTER, R. K., Transmission Characteristics of a Short-wave Telephone Circuit, *Proc. Institute of Radio Engineers*, Vol. XVIII, No. 4, April, 1930.

TELEVISION

and fading out of the carrier are likely to be exceedingly troublesome when picture signals occupying a wide-frequency band are utilized. The published reports concern themselves only with frequencies between 425 and 2,295 cycles, a considerably narrower band than would be required by a television entertainment service based on methods so far understood. The transmission characteristics of the radio telephone circuit were found to undergo exceedingly rapid changes, apparently due to wave interference between signals arriving over paths of a different electrical length and possibly combined with distortion produced by progressive change in the angle of rotation of the polarization plane with frequency over the signal band. The occasions when faithful transmission was observed were extremely rare. Considering the narrow band involved, as compared with that necessary for good television, the probability is that wire rather than radio channels will be used for television-broadcasting service.

In the effort to establish a reliable sound program service of features originating in England and on the continent, the National Broadcasting Company, through the Radio Corporation of America, has launched an elaborate series of experiments to combat the short-wave fading problem. Three extensive receiving aerial systems have been erected at Riverhead, Long Island. An automatic selector system connects the particular aerial which at each instant is delivering the most consistent and highest level with the circuit feeding the broadcasting system. An automatic volume control compensates for variations in volume. The level indicators give a clear

demonstration of the continual variations in signal encountered even with an extensive aerial system in an ideal location.

The ambitious character of the equipment and the installation required to secure the semblance of a reliable signal indicate the gravity of the transmission problem involved in the high-frequency broadcasting of television signals. If we resort to the ultra radio frequencies higher than thirty megacycles, we may be able to deliver a more stable signal, but then the skip-distance effect is likely to make long distance reception of the signal a virtual necessity. The possibility exists, however, that the ultra high frequencies may yield a band suited to reliable television broadcasting.

Effect of Selective Fading on Television.

When channels 100 kilocycles in width are considered, the liability to trouble from selective fading is enormously increased. Changes in the conductance of the transmission medium to various parts of the band being used for television transmission result in peculiar distortion. As the higher frequencies fall out, detail disappears, but silhouettes increase in contrast. When the opposite condition obtains, major areas of uniform shading tend to merge with the background, while detail of fine texture improves. The difficulties of transmitting broad bands of signals on high frequencies are of such a fundamental character that they seem to be practically incurable. They are the play of gigantic forces of nature on the highly responsive transmission medium. The solution of the problem lies in narrow-

ing the signal bands necessary to adequate television, rather than in any reliance upon broad frequency bands in the inherently unstable radio-transmission medium.

Echo Effects.

The echo effect is caused by the arrival of the signal at the receiving point through different transmission paths. This may be caused by response to electromagnetic waves reflected from various levels of the Heaviside layer or arriving from various directions out of phase.

Directional antennas at both the receiving and the transmitting ends may help to mitigate the reflection difficulties. Dr. Alexanderson mentions the ghost-like figures resulting from reproduction of the delayed signal when experimenting with transmissions from Schenectady at his home on Lake George. Ghosts were also observed in the famous Bell System demonstration between New York and Whippany, the only known public demonstration of radio television over a considerable distance performed on schedule.

Dr. Alexanderson describes his experiences with television reception during the summer of 1928 at Lake George, about fifty miles from Schenectady, as follows:

A difficulty particularly brought out by the Lake George observations is a phenomenon which may be described as "mirage." It is analogous to the mirage that can be seen over lakes in the morning and evening and results in the distortion of images and sometimes in the appearance of several interwoven images. It appears as if the reflecting

TRANSMISSION OF TELEVISION SIGNALS

Kennelly Heaviside layer, which we assume to be located about one hundred miles over the earth, were broken up sometimes in several layers at different heights, each reflecting a separate image and sometimes giving an irregular and blurred image.

The radio waves travel at the velocity of light, and though we are in the habit of thinking of this velocity as being almost infinite for anything that occurs on the earth, we find that these rays are too slow for television. Light travels at the rate of 186,000 miles per second, and yet we find that light will travel only about 200 miles in the time required for tracing one line in a television picture, and only 50 miles in the time required to trace one-fourth of a line in a picture. Thus, if two rays have traveled from the transmitting to the receiving station through different paths and the length of these paths differs by only 50 miles, they will register separate images differing as much as one-fourth of the picture. Each of these rays will then trace its own picture and we will have two pictures displaced by that amount. On the other hand, a multiplicity of rays will arrive having traversed different paths, each tracing its own picture, with the result that all the details of the picture appear blurred.¹

Reporting on experiments in radio transmission in New York City, particularly over short-wave channels utilized in television experiments, C. W. Horn, general engineer of the National Broadcasting Company, states:

The massive steel structures of New York present an unusual problem in transmission, particularly over short-wave channels, such as are utilized in television experi-

¹ Statement by Dr. E. F. W. Alexanderson, released by General Electric Company Press Bureau, September 4, 1928.

TELEVISION

ments and facsimile. The shorter the wavelength or higher the frequency, the more these waves take on the properties of light waves, in that they are easily absorbed, reflected and refracted. Consequently, they literally bounce around among the steel structures of New York. The experiments and tests have shown the reception of three, four and more distinct signals coming into receivers from different directions and over different paths. The actions of these waves, bouncing to and fro, sometime create definite shadows behind buildings and other edifices in which little or no energy might be detected. This effect is not very noticeable, if at all, in the broadcast transmission band, so the radio listener need not be worried, but the greatest effect at present on radio signals is in the extremely short wavelengths such as are used for television experiments.¹

It is quite possible that high-frequency television may be limited in scope to events comparable to those broadcast through international high-frequency circuits. When the news value of the subject matter is of sufficient interest to justify itself, even though it involves a loss in clarity of reproduction, the public will be content with a low quality standard but, for entertainment and educational purposes, the reproduction must be stable and of adequate detail. Apparently, this can best be accomplished through wire transmission over telephone and power-line circuits through the carrier method. So long as the signal bears a proper ratio to the noise level background, the wire system possesses important advantages from the standpoint of stability and

¹ Statement issued by Press Relations Department, National Broadcasting Company, November 25, 1930.

TRANSMISSION OF TELEVISION SIGNALS

attainable frequency characteristics. Considering that we have vast wire telephone and power networks extending into a large proportion of homes and used only for low-frequency purposes, the possibility of utilizing these facilities for television transmission is far from remote.



CHAPTER VII

RECEPTION OF TELEVISION SIGNALS

Conventional broadcast receivers are wholly unsuited to the reception of television signals, both because of the limited band width to which they respond and because television signals are not radiated in the broadcast band. The possibility of combining the requirements of television reception with broadcast reception in a single radio- and audio-frequency system are remote, specialized receiving methods being required for each of the two services.

Special Radio Receivers Required for Television.

For broadcast reception, the radio-frequency amplifier must admit a 10 kilocycle signal and exclude the signal of neighboring 10 kilocycle channels. A radio-frequency amplifier sufficiently selective to accomplish such discrimination tends to cut off the higher audio frequencies involved in musical reproduction. For television reproduction, the receiver must respond to much broader signal bands, ranging from 20,000 to 100,000 cycles in width, and consequently a tuning system of entirely different characteristics from those useful in broadcast reception is required to discriminate television signals.

The comparative selectivity required for broadcast music and television picture signals is indicated by the relation of the desired frequency band width

RECEPTION OF TELEVISION SIGNALS

to the signal frequency itself. At 1,500 kilocycles, the desired broadcast signal band of 10 kilocycles is 0.7 per cent of the signal frequency. A 100-kilocycle television band, at 2,000 kilocycles, is 5 per cent of the signal frequency. While television transmitters are not numerous and reception is restricted to short ranges, selectivity is not yet an important factor. But eventually the same standard of selectivity now obtaining in broadcast reception will be required for television service, although that standard, under the prospective conditions, will be somewhat more difficult of attainment.

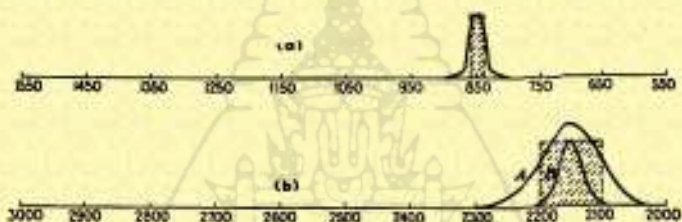

FIG. 34.—Selectivity requirements for television reception. Shaded area (a) shows response of an ideal broadcast receiver and the superimposed curve is the average response. The lower curve (b) shows the same order of selectivity applied to the television band. Curve A shows the effect of admitting substantially the entire desired signal to be high response to cross-talk from the neighboring channels. Curve B shows that essential elements of the picture signal must be excluded if cross-talk is to be avoided.

A receiving device employing an audio-frequency amplification system to be used for both television and broadcast reproduction and having two radio-frequency systems, one adapted to television and the other to broadcast purposes, also seems impracticable. When used for reproducing music an audio system

TELEVISION

responding to any band considerably more than 5,000 cycles wide amplifies disagreeable heterodyne interference which is excluded by an amplifier of suitably limited response. Consequently, neither the radio-frequency nor the audio-frequency amplifier of the broadcast receiver has characteristics suited to television purposes.

A further barrier to combined broadcast and television receivers arises out of the remoteness of the present television band from the broadcast band. The broadcast spectrum lies between 1,500 and 550 kilocycles (200 to 525 meters), while the experimental television channels lie between 3,000 and 2,000 kilocycles (100 to 150 meters). Between the broadcast and the television band, is an amateur band (1,716 to 2,000 kilocycles), and a mobile band, devoted to aviation, maritime and police services. These assignments are the result of international agreement and cannot be readily altered. The probability that these mobile and amateur services will be shifted so that broadcast and television bands may adjoin is remote. Furthermore, the channels now assigned to experimental television are likely to be required for extensions of the band assigned to aviation purposes when that form of transportation is more extensively used. If still wider bands than 100 kilocycles are found necessary to television of commercial quality, it is more likely that the television band will be moved than that other services will be transferred to accommodate it.

Television broadcasting, without accompanying sound, offers but a small proportion of the entertainment value of combined sound and visual programs.

RECEPTION OF TELEVISION SIGNALS

Although the popularity of sound motion pictures is substantiating evidence of this fact, it hardly indicates how essential accompanying sound is to the television program. The motion picture without sound offered a very high standard of reproduction and was produced by a specialized and capable technique. On the other hand, television is likely to represent a low standard of visual reproduction, at least in its initial stages, so that sound accompaniment will be practically essential as a supplement to and embellishment of the entertainment offered the eye. The most likely development of television communication is therefore the use of broad signal channels which will not only transmit picture signals but will also handle synchronizing frequency and sound accompaniment as well. This combination signal will actuate receiving systems equipped with means of filtering each of the three signal components so that they may be employed for their respective purposes of visual reproduction, sound reproduction and speed control.

Radio-frequency Amplifiers for Television Reproduction.

The usual practice has been to employ single-tube short-wave radio receivers for intercepting experimental broadcasts, subjecting their output to three or four stages of resistance-coupled amplification. While this method overcomes the problem of broadband interstage coupling, such receivers are almost invariably regenerative, whether equipped with regeneration controls and feed-back coils or not. Regeneration cuts off the higher frequencies so that,

TELEVISION

no matter how good the audio-frequency amplifier, fine shading details in the transmitted picture signal are certain to be suppressed before they can be reproduced. If the tendency toward regeneration is avoided, then the sensitivity of the single-stage radio-frequency system is of such a low order that reception range is greatly limited. The one-tube arrangements are strictly limited in their application to narrow-band television reception, in the order of 10 kilocycles or less.

For the reception of signal bands of 20 kilocycles or more, the conventional tuned radio-frequency amplifier must be substantially modified from the familiar broadcast designs. Having to admit a broad band of signals, the tuned radio-frequency receiver is likely to respond to signals radiated on neighboring channels, unless special design precautions are taken to overcome its inherent lack of selectivity when adjusted for broad-band response. Radio-frequency amplifiers, adapted to passing broad bands of signals are required for television purposes, such as band-pass filter systems and special super-heterodyne receivers.

The Band Selector.

The band selector is a system of reactances so related to each other that they are balanced at any frequency within a desired band. Outside of the limits of this band, the reactances are unbalanced, offering a high overall reactance. Two reactance couples, X_1 and X_2 (Fig. 35), are balanced within themselves at the same frequency and coupled to reactance X_3 , common to both. When the impressed

RECEPTION OF TELEVISION SIGNALS

frequency is that at which reactance couples X_1 and X_2 are balanced within themselves, the overall reactance of the circuit is zero. The current at that frequency traverses X_1 and X_2 without passing through X_3 . At any other frequency, however, there will be a potential difference between points a and b , the terminals of the bridging reactance X_3 . If the frequency is lower than the balance frequency, the reactance is capacitive; if higher, it is inductive. Under the latter conditions, the inductive reactance tends to equalize the unbalanced capacitance of branches X_1 and X_2 , provided that the combined

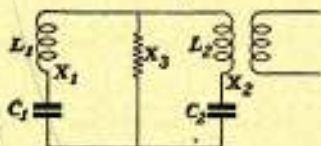

FIG. 35.—Schematic diagram illustrating principle of band-selector tuning.

reactance is no greater than that of X_3 . In that case, current will flow through X_3 of such amount that the reactive electromotive force across ab due to the currents in X_3 is equal to that due to the currents in X_1 and X_2 . The energy delivered to the output circuit will then be equal (neglecting the resistances in the circuit) to that delivered when the applied frequency is that at which the circuits are mutually balanced. If the applied frequency is lower than the balance frequency, the capacity reactances in X_1 , X_2 and X_3 combine instead of tending to neutralize, thus offering a high reactance to the signal. By a proper selection of reactance X_3 , the width of band offering substantially zero reactance can be controlled to meet any specific requirements.¹

¹ VREELAND, DR. F. K., Distortionless Reception, *Proceedings Institute of Radio Engineers*, Vol. XVI, No. 3, March, 1928.

A spaced amplifier may be used to amplify the output of the band selector. The spaced band amplifier consists of a number of stages of tuned radio-frequency amplification, each stage being slightly detuned in such a manner that the composite result is the amplification of a band of frequencies. Such

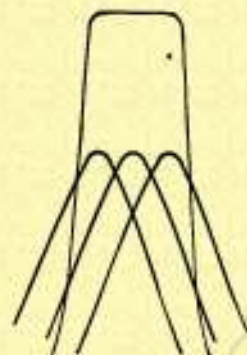

FIG. 36.—Overall response curve of a spaced band amplifier.

an amplifier may consist of three tuned stages, each individually having the characteristic inverted V-type resonance curve but spaced slightly apart with reference to the others, so that the overall amplification secured has the desired band characteristics, as shown in Fig. 36.

The Superheterodyne Receiver for Television Service.

The superheterodyne principle of reception is especially well adapted to the needs of television reception because this type of circuit has the advantage of discriminating strongly against signals on neighboring channels without any sacrifice of stability. Furthermore, the incoming signal can be altered to a frequency such that a 20 kilocycle band, for example, is reduced to a small proportion of the intermediate frequency. The Bell Telephone Laboratories employed a superheterodyne receiver to pick up a 1,575-kilocycle picture signal at New York, 22 miles from the transmitter at Whippany, N. J. This signal was impressed upon the output of a 6,575-kilocycle oscillator and the 5,000-cycle com-

RECEPTION OF TELEVISION SIGNALS

ponent isolated by a selector circuit. The advantage of this method is obvious when it is realized that a 20-kilocycle band at the transmitted frequency of 1,575 kilocycles represents 2.6 per cent of the band, while at 5,000 kilocycles, the same frequencies represent but 0.8 per cent. It is therefore possible to employ materially sharper circuits without discriminating against the higher picture-signal frequency components. The 5,000-kilocycle circuit is combined with a 5,120-kilocycle oscillator which, in turn, feeds 120 kilocycles through a two-stage intermediate-frequency amplifier.

The only commercial receiver so far developed especially for television purposes is made by the Jenkins Television Corporation. Its tuning range is from 100 to 200 meters (3,000 to 1,500 kilocycles). Three stages of screen-grid radio-frequency amplification are rectified by a non-regenerative power detector. This feeds into a two-stage resistance-coupled audio amplifier, also utilizing screen-grid tubes, while the final power output stage employs a 245-type power tube. The audio-frequency amplifier handles a range of 15 to 30,000 cycles.

Radio-frequency Amplification of Picture Signals.

Regardless of the method employed to select the modulated radio-frequency signal and to amplify it before the picture signal is separated from the carrier, further amplification of the picture signal is necessary to actuate the light reproducer. The customary method is to employ resistance-coupled amplification for television purposes, although, as iron-core transformer design has evolved, the resist-

ance amplifier has been virtually displaced in broadcast reception.

Figure 37 shows two tubes coupled by a resistance and capacity. The impedance of the plate circuit of the first tube is large compared with the plate resistance of that tube. In other words, the equivalent impedance of R_1 shunted by R_2 and C_1 must be large compared with the plate resistance R_p . The coupling capacity should be the smallest which will

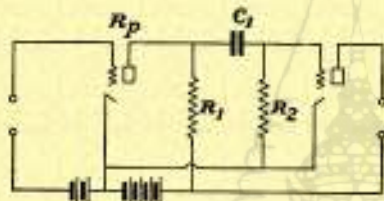

FIG. 37.—A resistance-coupled amplifier.

transmit the lowest frequency required, because the impedance falls for all higher frequencies. The useful voltage output of the first tube is that developed across R_2 im-

pressed on the grid of the second tube. The larger the capacity of the coupling condenser, the more nearly the amplification of the lower frequencies approaches the maximum attainable for a tube of a given amplification factor. On the other hand, the larger the capacity of the coupling resistor, the smaller the amplification of the high frequencies. Consequently we are constrained to use small coupling condensers for broad-band response at the expense of gain per stage. Since substantial outputs are necessary for the television illumination system, the inefficiency of resistance-coupled audio-frequency amplifiers makes the use of three and four stages essential. Screen-grid tubes and, prospectively, pentodes promise continued progress in amplifier design,

RECEPTION OF TELEVISION SIGNALS

certain to keep pace with the development of television service. The tendency is, therefore, to employ equalizing networks as a means of correcting high-frequency losses.

Prospective Developments Affecting Television Receiver Design.

Recent developments in core materials for magnetic transformers foreshadow the availability of audio-frequency amplification systems capable of handling the broad bands necessary for television picture signals. For amplifying the 40,000-cycle picture-signal band used in the two-way television system, the Bell Telephone Laboratories employed output and input transformers with a newly developed chrome permalloy core material. The high gain per stage possible with such transformers makes them decidedly superior to any resistance-coupled system.

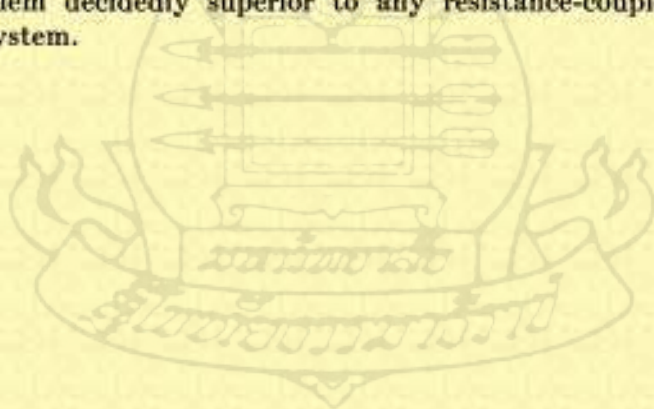

CHAPTER VIII

CONVERTING THE PICTURE SIGNAL INTO LIGHT

Embodied in the transmitted picture signal are two elements of information: intensity, representative of shading, and relative time, representative of position. Reproduction of the television signal is, therefore, a twofold function; first, varying light proportionate to signal intensity, and second, the placing of each light impression in its proper position in the field of reproduction.

The Neon-glow Tube.

The neon tube is generally used for converting the picture signal into corresponding light. Its cathode is a flat metal plate, slightly larger in area than the field of reproduction. The anode is a similar plate, usually separated from the cathode by a distance of approximately one millimeter. With correct pressure of neon, and suitable spacing of the plates, the cathode dark space is equivalent to the separation of the plates, causing the luminous discharge to develop on the outer one. The illumination should be a thin, uniform, brightly glowing layer proportionate to the signal voltage. The neon-glow tube has proved itself to be adequately responsive for

CONVERTING THE SIGNAL INTO LIGHT

television reproduction of the most advanced systems so far developed.

The light output of a neon tube bears a linear relation to the applied current supplied over a wide range. The curve shows the characteristics of a neon tube, known commercially as the kino lamp made by the Raytheon Company. It produces approximately 0.14 candle per milliampere which, diffused over a plate of this size, offers a brilliance of 0.03 lambert per milliampere. The change is constant throughout a wide range of applied voltages. A suitable plate potential conveniently secured from radio B batteries, maintains a fixed potential difference between anode and cathode of a value at which a slight increase in voltage produces substantial increase in illumination. The makers of the kino lamp recommend a minimum "dark" current of 10 milliamperes. Although the apparent resistance of the kino lamp is 500 ohms, it functions satisfactorily in the plate circuit of conventional radio output tubes, such as the 171-A or the 245. Better results are, of course, obtained by matching the output load of the vacuum tube with the impedance of the tube itself. It is customary to use a series resistor as a protective device in order to limit the current

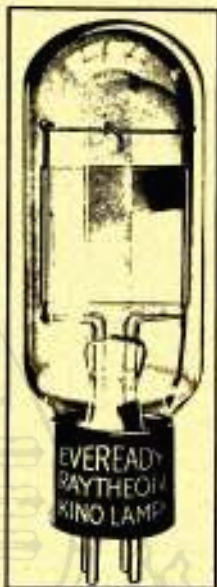

FIG. 38.—A neon-glow tube for direct observation through a scanning disc.

TELEVISION

flowing through the neon tube. The use of excessive direct-current output shortens the life of the tube and produces no proportionate gain in the contrast between minimum and maximum picture signal.

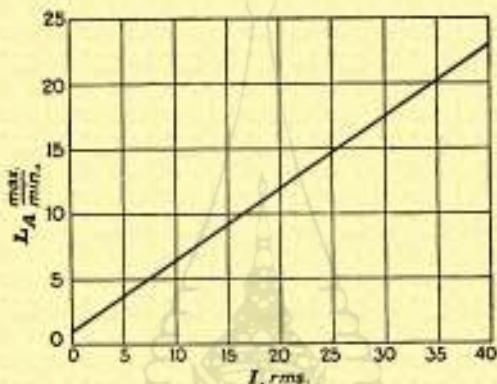

FIG. 39.—Brightness variation of Raytheon neon-glow tube with alternating-current change.

Larger Neon Tubes.

Neon tubes of this general design are satisfactory for small television outfits. However, as the illumination of the field of reproduction and its area increases, dissipation of the heat attendant upon making the neon luminous becomes a problem. Satisfactory 48-line reproducers have been made with the conventional type of neon tube, but water cooling of the neon tube was found necessary with a 72-line system of the Bell Laboratories. Figure 40 shows the rather complex neon tube developed for the Bell reproducer used in the first demonstration of two-way television.¹ The average plate current

¹ See pages 39-41, 101, 155-157.

CONVERTING THE SIGNAL INTO LIGHT

through the tube is 200 milliamperes. In order to maintain stable operation, a source of hydrogen is continuously connected with the tube to maintain a carefully regulated pressure.

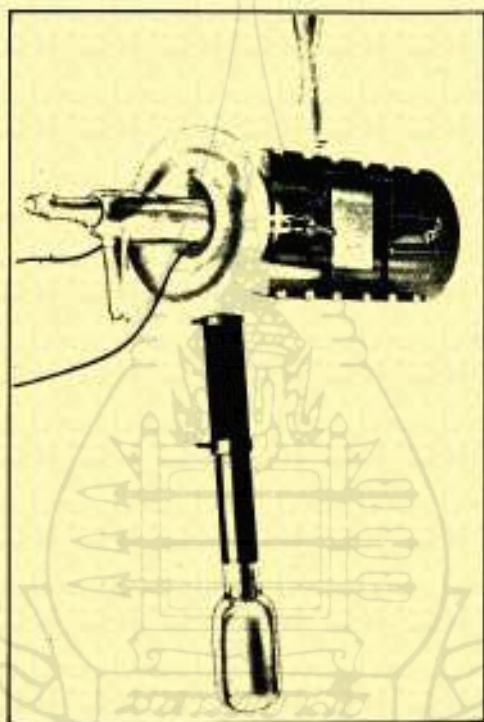

FIG. 40.—The water-cooled neon-glow tube used in the Bell Laboratories demonstration of two-way 72-line wire television.

Every known means of producing controlled light requires the generation of a considerably larger amount of energy in heat. Dependence upon luminous gas discharge through a simple tube requires that the entire field of reproduction be illuminated and

TELEVISION

that observation be restricted to the particular picture element being reproduced. Consequently, the tube used must be capable of generating the maximum light required for bright illumination of a single picture element, multiplied by the total number of picture elements in the field of view. Hence it is not difficult to arrive at a point where the heat generated is far in excess of that which can be radiated by a self-cooling device. As we become concerned with a larger number of picture elements, therefore, it appears to be practically essential that all of the light energy produced by means of the picture signal be concentrated upon the illumination of each picture element in the field of reproduction only for the interval that it is to be observed. Dissipation of light over the entire area of reproduction when only one picture element is observed at a time constitutes a waste of energy which cannot be tolerated in commercial practice.

A new type of neon tube developed by the Bell Telephone Laboratories has successfully circumvented this wasteful practice. The tube has a small aluminum electrode rather far back from the front of the bulb. A lens mounted in front of the tube, together with a system of lenses mounted spirally in a scanning disc carries all of the light produced directly to the eye. This is indeed an efficient optical arrangement producing a brighter image with a much smaller current passing through the neon tube. In fact, the small aluminum anode is screwed into a large copper cylinder and this alone provides sufficient cooling to make it possible to dispense with the water-cooling system.

CONVERTING THE SIGNAL INTO LIGHT

Color of Neon Illumination.

The luminous discharge of the neon tube is orange in character, a part of the color spectrum to which the eye is not particularly sensitive and which tends to cause fatigue. In experimenting with the possibilities of color television, Dr. Herbert E. Ives has produced an argon tube quite similar in design to the neon tube, which produces illumination rich in the green and blue elements of the spectrum. A picture signal is transmitted for each of the three prime colors and reproduced by two argon tubes and one

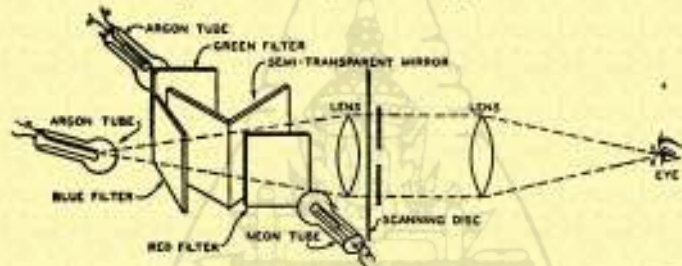

FIG. 41.—The Bell Laboratories color-television reproducer. Red, blue and green components are provided by one neon and two argon tubes with the assistance of suitable filters. Mirrors serve to blend the three controlled light sources into a single beam which is observed through a scanning disc.

neon tube. The resulting images are optically blended to form a single image successfully combining the components of red, yellow and green in their correct proportions to produce very remarkable and vivid color television. This was demonstrated in May, 1929, with a 50-line system.¹ Figure 41 shows the optical system necessary to combine the three colored images into one for the observation of the looker-in.

¹ IVES, HERBERT E., *Television in Colors*, *Bell Laboratories Record*, Vol. VII, No. 11, July, 1929.

TELEVISION

The Drum Scanner.

C. Francis Jenkins of Washington, D. C., has produced the drum scanner, which is more economical of energy at the reproduction point and also dispenses with most of the inconvenience of the scanning disc. The neon tube in Jenkins' drum scanner has four elements to which contact is made successively through a rotating commutator arrangement. The apertures through which the observer sees the light are arranged on a cylinder 7 inches in diameter, 3

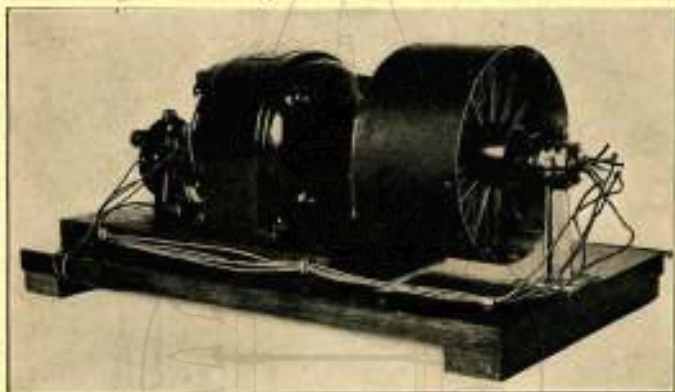

FIG. 42.—Jenkins' drum scanner with multiple neon-glow tube. The light is conducted to the apertures through quartz rods.

inches long and $\frac{1}{16}$ inch thick. Forty-eight scanning apertures are punched in the drum, four helical turns with the holes spaced 2 inches apart and with $\frac{1}{2}$ inch between helices. Quartz rods which rotate with the drum conduct the light from the individual targets within the neon tubes to the drum apertures. The light loss in the inverse square law is thus avoided and the energy which would be dissipated is cut by

CONVERTING THE SIGNAL INTO LIGHT

three-quarters. Quartz conducts the light from the target to the aperture without loss of light energy. By using six helical turns and six targets, a 3-inch picture is produced, while a $10\frac{1}{2}$ -inch drum in six revolutions per picture produces a 4-inch square reproduction.

One of the advantages inherent in the drum scanner is the fact that the apertures exposing the illumination sweep in a straight line before the eye. The image

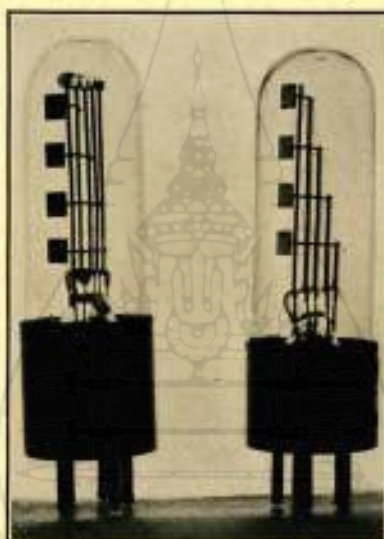

FIG. 43.—A four-element neon tube used in Jenkins' drum scanner.

produced by apertures in a disc are made up of curved sweeps, the radius of which is determined by the distance from aperture to disc center. Obviously, an image made up of straight parallel lines is more easily interpreted than one composed of curved lines.

The television reproducers being offered experimenters are, more and more, of the drum design. The

TELEVISION

quartz rod and the multiple-element glow tube have not, however, made as rapid progress as the drum feature of the Jenkins design. The drum has the

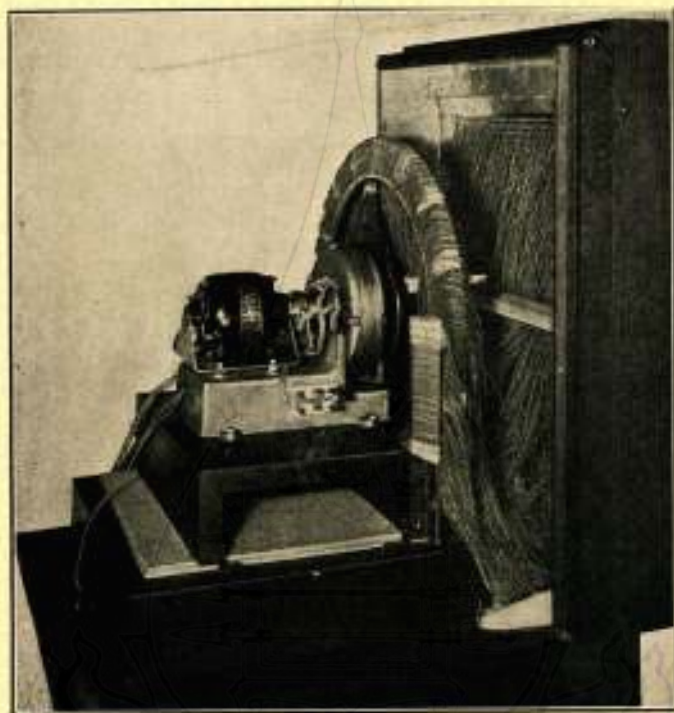

FIG. 44.—The rotating switch system which distributes the picture signal to the 2,500-element neon tube and opens and closes approximately 40,000 circuits per second.

advantage of mechanical compactness, making possible 60-line home reproducers of practical proportions.

The Neon Grid Screen.

One of the most interesting forms of picture-signal reproducer developed is the Bell System grid screen,

CONVERTING THE SIGNAL INTO LIGHT

which has the advantage of illuminating each picture element individually as the impulse for it appears in the picture signal. It consists essentially of a single long neon tube, turned back and forth upon itself, making 50 parallel sections. The interior electrode is a spiral wire while 2,500 external electrodes of metal foil, cemented outside the tube, each repre-

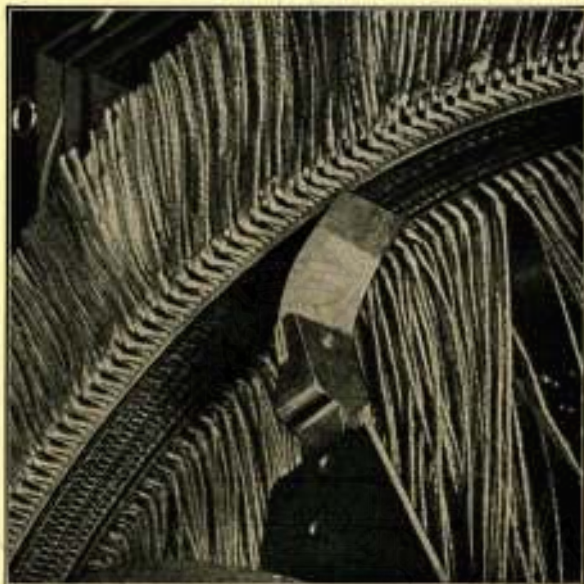

FIG. 45.—The brushing contactor which completes the circuit to the 2,500 elements of the neon-grid screen.

sentative of a picture element area in the field of reproduction, form the facing electrode. The picture signal is distributed to the 2,500 external electrodes one at a time through a contactor arm, the motion of which is synchronized with the scanning of the transmitter. The heat energy produced is small because only one picture element is illuminated

TELEVISION

at a time and no power is utilized in light production except where it is observed by the eye. The contact distributor is naturally a rather costly device, and it is difficult to imagine it as an element of a single home receiver, particularly if considerably more than 2,500 picture elements are produced. It was this device which was demonstrated by the Bell Laboratories



FIG. 46.—The complete grid screen in its frame.

as screen projected television, a demonstration in which Herbert Hoover, then Secretary of Commerce, participated in June, 1927.¹

The Cathode-ray Tube.

The Braun cathode-ray tube has long been considered as a possible source of controlled light for

¹ See pages 38-39, 77, 98-99, 153-155.

CONVERTING THE SIGNAL INTO LIGHT

television reproduction. The cathode-ray tube is a high-vacuum tube, the anode of which is punctured with a small pinhole. Electrons, released from a hot cathode, are directed, at an exceedingly high velocity, to the anode as a result of a high plate potential. Normally, the electron stream is conducted off the plate, with the exception of the increment which falls to a pinhole in the anode. This component of electrons is directed to a fluorescent screen, usually a coating of zinc sulphide, at the far end of the tube, which forms a second anode. The tiny pin-point stream of electrons is readily diverted as a result of magnetic and electrostatic influences. By applying voltages to two plates, set at right angles to each other, between the first and second anodes, the electron stream produces visible patterns on the fluorescent screen. There are no mechanical or moving parts and the device is sufficiently responsive to make possible observations of frequencies higher than a million.



FIG. 47.—Close-up view of the neon grid screen, showing the continuous grid element and some of the 2,500 elements of heavier wire connected with the switch points.

TELEVISION

The use of the Braun tube for television purposes was suggested by Campbell Swinton as early as 1908. Various workers in Europe and America have experimented with cathode-ray television reproducers but their exceedingly high cost and short life have stood in the way of producing anything practical up to this



FIG. 48.—Dr. V. K. Zworykin examining the cathode-ray television tube which he developed at the Westinghouse laboratories.

time. Dr. Zworykin of the Westinghouse Company has recently built a special cathode-ray tube for television purposes. It is of the usual conical form, playing the cathode ray upon a screen sufficiently large to produce an image 3 inches square. There are two anodes, the first being the controlling element,

CONVERTING THE SIGNAL INTO LIGHT

operating on 300 to 400 volts plate potential. The amplified picture signal is used to cause variations in the plate voltage which are translated into cathode-ray intensities. A second anode accelerates the pencil of electrons escaping through the first anode by means of a potential of 3,000 to 4,000 volts, focusing the beam to a sharp spot on the target which is 7 inches in diameter. The fluorescent material is Willimet, which is made slightly conductive so as to leak off the charge produced by the electron screen.

Distinction between a Light Valve and a Variable Light Source.

While the neon tube and the cathode-ray tube appear to be adequately rapid to reproduce any television signal for which communication channels are available, they seem incapable of producing adequate intensities for projection purposes so that large audiences can be served. If illumination is restricted to one picture element at a time, as with the Bell television multiple-element screen, the distribution system becomes exceedingly complex and delicate, particularly when the number of picture elements necessary to a commercial entertainment service is considered. On the other hand, if we rely on total illumination of the field of view but restrict observation to a single elemental area, the neon system required for the equivalent of screen projection becomes of tremendous magnitude.

The desirable procedure is the use of a light valve having means of controlling the amount of light projected on a screen from a powerful local source of light in response to a relatively small control voltage.

TELEVISION

The function of the amplified picture signal then becomes merely one of controlling the output of a fixed light source, a distinctly more reasonable task than that of being the energy source for the projected light itself.

The Kerr Principle.

Any mechanically controlled shutter cannot be expected to operate at the high frequencies encountered in television communication. This leads logically to the conclusion that a non-mechanical method capable of high-frequency operation, such as one of the Kerr effects, can be utilized to advantage. John Kerr, a coworker of William Thomson (Lord Kelvin), the eminent English physicist, observed that double refraction occurs when a beam of polarized light is passed through a strong electrostatic field. The component polarized in the direction of the electric force acquires a wave velocity slightly different from that transversely polarized. The effect produced is proportional to the square of the force across the condenser.

Kerr's conclusions were published by him in 1875. His discovery followed logically upon that of Faraday, who had observed that the direction of polarization of a polarized light beam can be rotated by submitting it to an intense magnetic field. The first practical television projector, depending on the Kerr effect and utilizing a light valve due to Dr. Karolus of Germany, was demonstrated by Dr. Alexanderson of the General Electric Company at Schenectady in May, 1930. It is a remarkable instance of the vision of Paul Nipkow, to whom is due the funda-

CONVERTING THE SIGNAL INTO LIGHT

mental principle of dissecting the field of view by scanning through a spirally apertured disc, that he outlined the method of utilizing Faraday's magnetic deviation of polarized light for projecting images on a screen. Without the aid of vacuum-tube amplifiers and experience in handling high-frequency magnetic fields, it was obviously impossible for Nipkow to embody his disclosure in practical form.

Inasmuch as the use of polarized light is destined to play a significant part in the development of practical television service, the principles involved should be understood by the student of television. Undoubtedly, new applications of great importance to television will be made of the phenomena of polarization.

Polarized Wave Energy.

A spot of light, projected on a screen, is produced by a stream of light energy set up by a myriad of tiny transmitters constituting the light source. Light from a candle is secured by oxidation of numerous tiny particles of the wick. The illumination of a tungsten filament of the conventional electric-light bulb is produced by uncounted millions of atoms, each heated to incandescence by an electric current. However small a beam we secure even from a so-called point source of light, an immense number of separate sources contribute their quota to the total illumination produced.

Light is a wave motion which may be likened to the waves of the sea or to the wave which a man may impart to a rope by a swing of his arm. The rudiments of polarization can be demonstrated by means of a simple set-up consisting of a rope twenty or thirty

feet long, fastened at one end to a post or wall and swung in various ways from the other. When the wave in the rope reaches the post, it tends to pull the post toward the man until the peak of the crest is reached and then the receding portion of the wave motion tends to push the post away from him. It makes no difference whether the wave is produced by swinging the arm horizontally or vertically or diagonally, a similar effect is produced at the hitching post. In any case, the direction of propagation is toward the post and the wave motion is at right angles or transverse to the direction of propagation.

If a fence with a vertical slit cut through it, just wide enough to permit the rope to swing freely, is erected halfway between the hitching post and the man swinging the rope, energy can still be imparted to the hitching post, so long as the man swings the rope vertically. The effect of the slit is to limit the type of wave motion which can be transmitted beyond it to a vertical wave form or, as it is termed, to vertically polarized waves. If, on the other hand, the slit is cut horizontally, only horizontally polarized waves can be made to reach the pole; every other type expends its energy upon the obstructing fence.

Polarized and Unpolarized Light.

Unpolarized light, being produced by a tremendous number of uncoordinated transmitters or sources, includes wave motion of every conceivable type, horizontal, vertical and in every intermediate position between these limits. Certain crystals are of such construction, however, that light-wave motion in only one or two directions can be projected through

CONVERTING THE SIGNAL INTO LIGHT

them. When light is projected through a crystal of Iceland spar, its path is refracted into two rays. One ray obeys the regular optical laws and is called the *ordinary ray*; the other is called the *extraordinary ray*. Both rays remain parallel to the optical axis of the crystal. If the crystal is rotated about its optical axis, the ordinary ray will remain in a fixed position but the extraordinary ray will describe a circle. If the ordinary ray is projected through a second crystal, it will again divide into two rays, the ordinary and the extraordinary. The distribution of light energy between the two rays projected through the second crystal is determined by the angle of pro-

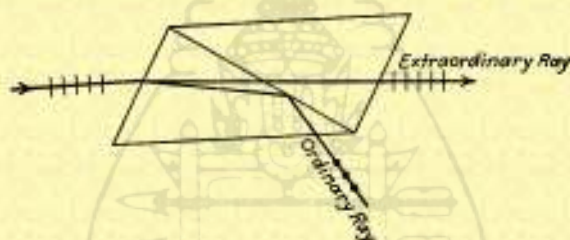

FIG. 49.—The Nicol prism, showing deflection of the ordinary ray.

jection of the polarized ray to the axis of the crystal. By rotating the crystal through 90 degrees, each ray will go through a cycle from zero to maximum. The same effect is produced by changing the angle with which the polarized ray is projected on a fixed crystal.

A Nicol prism is an optical device so designed that the ordinary ray is totally deflected and only the extraordinary ray remains. It is a convenient and efficient method of producing plane polarized rays.

The Karolus Valve Projector.

The screen television projector built under the direction of Dr. Alexanderson of the General Electric Company, utilizes the Kerr effect and is known as the Karolus projector. A powerful light source, a standard commercial motion-picture arc, is first concentrated into a beam by means of a lens system. The water cell (Fig. 50) conducts off the heat of the arc. The light beam is then passed through a Nicol prism so that it is separated into two components at right

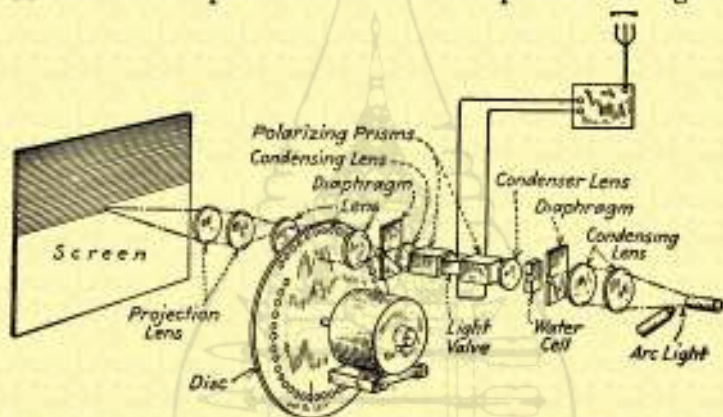

FIG. 50.—The Karolus cell projector lens system which produced a 6-foot image on the screen of a Schenectady theater.

angles to each other. The plane polarized ray is then passed through a container of nitrobenzol, which serves as the dielectric of a condenser. The picture signal received from the television transmission station, suitably amplified, is applied to this condenser, with the result that the polarized light beam is doubly refracted. The applied field may be considered to produce a phase shift between the two components of

CONVERTING THE SIGNAL INTO LIGHT

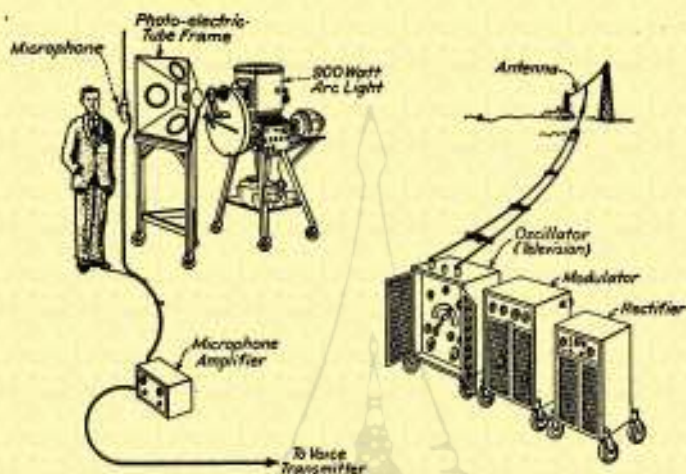

FIG. 51.—Schematic diagram of the transmitting equipment employed in the Karolus projector demonstration conducted by the General Electric Company.

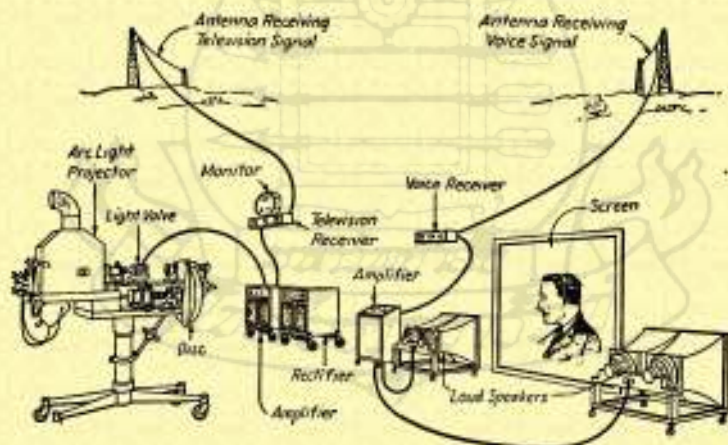

FIG. 52.—Schematic diagram of receiving end of television demonstration using the Karolus projector.

TELEVISION

the plane polarized light. The second Nicol prism is set at an angle such that no light is transmitted through it when there is no electrostatic strain in the nitrobenzol. Consequently the application of potential on the condenser causes light to be transmitted through it. For small angles of phase shift, the transmitted light is proportional to the fourth power of the applied voltage. This relation being far from linear, it is necessary to work the device over the upper and somewhat restricted portion of its characteristic to avoid the distortion resulting from its non-linear properties. Such operation, in turn, involves a sacrifice of contrast. However, the system forms an entirely non-mechanical light relay capable of working at extremely high speeds, readily controlled by a television signal. The resultant light is projected to a translucent screen through a scanning disc which is synchronized with the scanning disc at the pick-up point.

The results accomplished in the initial demonstration of this device indicated that means have been developed for screen projection for a large audience of as good quality as that attained with individual peephole reproduction. The screen used at Schenectady was 6 feet square and the illumination attained about half that of the ordinary motion picture. The audience, seated 50 feet or more from the screen, found the reproduction of 48-line television to be about the same quality and intelligibility as if it were reduced to but 1 inch square and viewed 10 inches from the eye. Projection, however, made possible the serving of a large audience instead of a single observer, a fact of great economic importance.

CONVERTING THE SIGNAL INTO LIGHT



FIG. 53.—The Karolus cell television projector developed in the General Electric Laboratories under the supervision of Dr. E. F. W. Alexanderson.

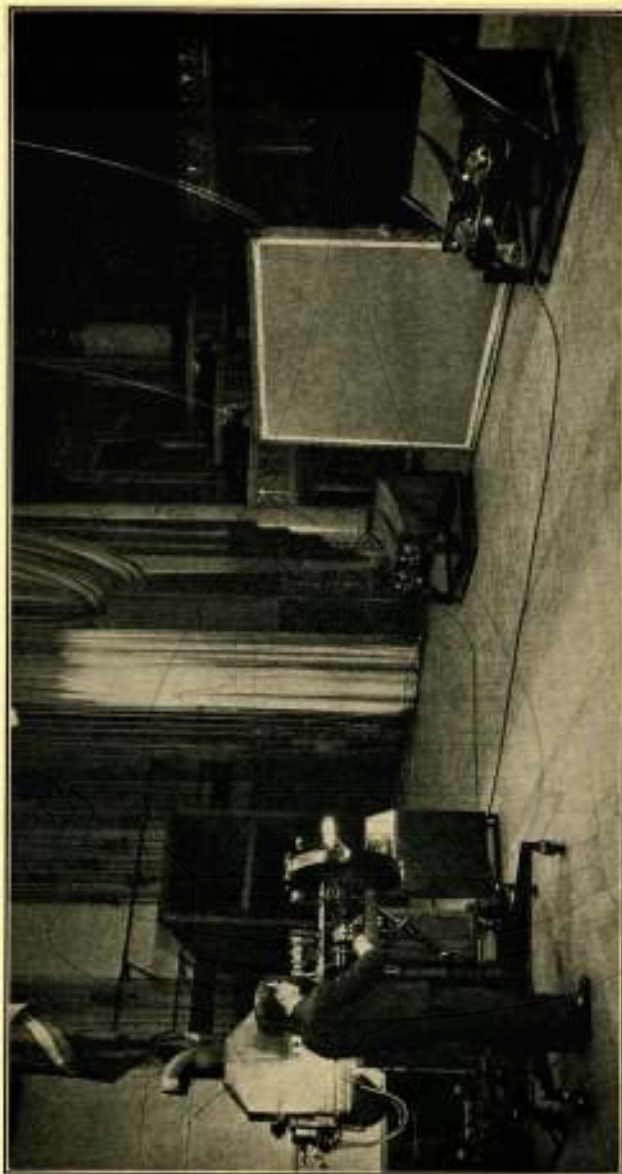

FIG. 54.—The screen, loudspeakers for sound reproduction and the Karolus projector on the stage of the RKO theater in Schemoctady.

CONVERTING THE SIGNAL INTO LIGHT

With such an extensive variety of methods for converting the picture signal to light, the designer of television reproduction systems has a wide latitude and a wealth of possibilities with which to work. Up to this time, the neon tube has been utilized almost exclusively but undoubtedly some of the alternative devices, such as the cathode ray and the Karolus valve, will ultimately prove their merit.



CHAPTER IX

FORMING THE IMAGE IN THE FIELD OF REPRODUCTION

The final process in television reproduction is the projection of the fluctuating light produced in response to the picture signal so as to form the moving image in the field of reproduction. It is the reversal of the scanning process, the reconstruction of the light impulses from their series to their original parallel arrangement.

The elementary method of accomplishing reconstruction is to reverse the scanning process by means of a disc identical in construction with that used to break down the field at the transmission point. For 24- and 48-line television, discs of a diameter convenient for home reproduction are easily made, and they have been used successfully for exposing a 72-line image.

The signal controlled light is spread over the entire field of reproduction and viewed by the observer through the scanning disc so that his eye response is localized at each instant to the particular picture element being reproduced. This is at present the conventional method of television reproduction but, because of its limitations, the scanning disc neon-tube combination is likely to be displaced by more flexible methods.

FORMING THE IMAGE IN REPRODUCTION

Alternative methods of distributing the light impressions in the field of reproduction have already been developed, and others will undoubtedly appear. The cathode-ray tube, described in the preceding chapter, accomplishes control over illumination intensity by varying the voltage on the anode and distribution of the fluctuating signal so produced by electrostatic deflection. Another alternative method is the employment of a separate source of illumination for each picture element, as with the Bell System neon-tube screen. The complex switching system necessary with a contact for each picture element reproduced militates seriously against its use for high-quality television in the home.

The Minimum Repetition Rate.

Regardless of the method employed to distribute the varying light corresponding to the picture-signal fluctuations in the field of reproduction, the same visual process is relied upon to collate the separate picture-element impressions into a complete image. The fluctuating light ray describes a path in the field of reproduction corresponding to the scanning pattern at the transmission point. The rapidly traveling ray brushes the reproducing surface in a series of parallel sweeps covering the entire surface within so short a time that the eye collates the sum of impressions into a single image. The scanning cycle must therefore be completed, regardless of the number of picture elements, within the period that persistence of vision makes possible observation of the first, last, and all the intervening picture-element impressions as virtually simultaneous. Although a bright impres-

TELEVISION

sion may affect vision for $\frac{1}{10}$ second or more, the brilliance and contrast attainable in artificial reproduction make $\frac{1}{20}$ second about the maximum time which can be allowed for the reproduction of a single frame if no flicker is to be experienced.

Limitations of the Scanning Disc.

There are two important limitations to the conventional scanning disc neon-tube combination which tend to prevent its use in home reproduction of high-quality television. First, the entire field of reproduction is illuminated for each picture element, although only one is actually observed at each instant; and second, for discs of reasonable proportions, good quality reproduction is limited to peephole size. Although the image produced by the conventional method may be optically enlarged, this involves loss of illumination and does not increase the information furnished to the eye. The amount of illumination available with existing neon tubes, particularly when the entire field of reproduction must be illuminated for each picture element, is too small to permit distribution over a larger surface, with the attendant reduction in brilliance.

If we attempt the use of neon tubes with larger reproduction areas for observation without the aid of a lens system, such as 4 by 5 inches in size, the scanning disc assumes unwieldy proportions. Each successive aperture in the spiral must then be separated by the total width of the field of reproduction. For a 4- by 5-inch reproduction, broken down to 100 lines, the scanning disc must therefore have a diameter of nearly 12 feet. With 20 repetitions, the rate of rotation of

FORMING THE IMAGE IN REPRODUCTION

such an unwieldy disc is 1,200 revolutions per minute, giving it a peripheral speed of 10 miles per minute, a speed far greater than is tolerable in any home device. Obviously, we cannot use discs of such proportions in general practice and must rely on enlargement of a small image by means of a lens system. This, in turn, requires a high order of mechanical accuracy in manufacture and neon tubes of more than the ordinary surface brilliance.

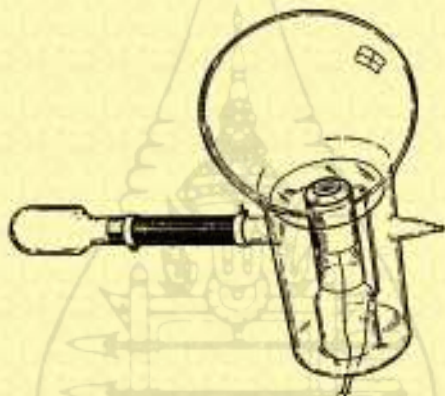

FIG. 55.—A neon-glow tube producing highly concentrated illumination sufficient for projection to the eye, developed by the Bell Telephone Laboratories.

The concentrated illumination neon tube described on page 106 developed in the Bell Laboratories overcomes this inefficiency of the flat plate type tubes by projecting its entire illumination to the eye through a lens system arranged in a scanning disc. Thus the entire effective illumination of the neon tube is used to reconstruct the image.

Utilizing the grid-type neon tube with a separate control electrode for each picture element, we over-

TELEVISION

come the illumination intensity problem, but find ourselves burdened with a mechanical switching

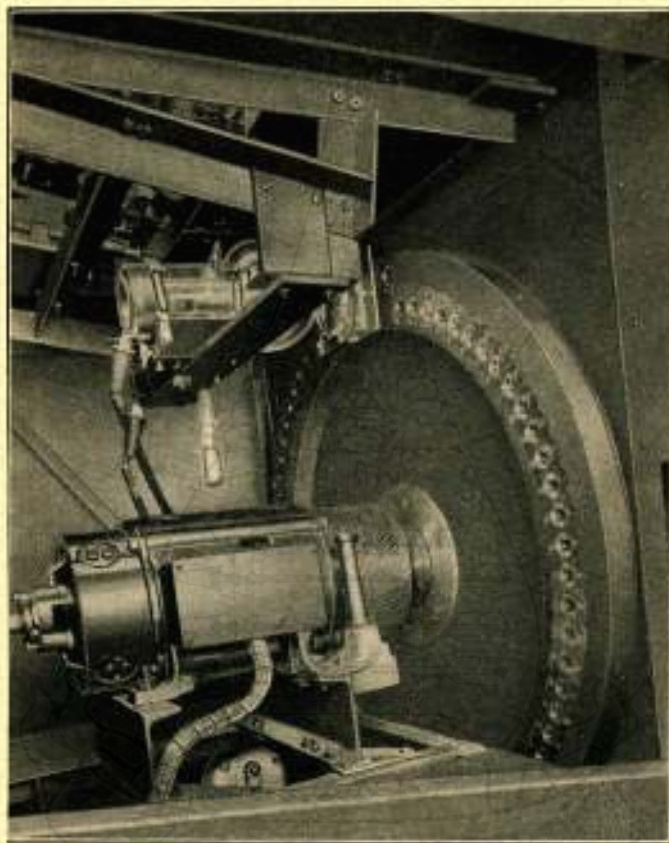

FIG. 56.—The optical system which projects the concentrated illumination output of the neon-glow tube to the eye. A large collecting lens gathers most of the light flux which is projected to the eye through the lenses of the scanning disc.

system which assumes discouraging proportions for a finely divided field of reproduction. The conclusion

FORMING THE IMAGE IN REPRODUCTION

seems inescapable that any mechanical system of light distribution, such as scanning discs or switching methods, fails to meet the requirements of a system involving more than 5,000 or 10,000 picture elements per frame. The prospective solution is the control of a fixed powerful light source, as with the Karolus cell, or a flexible non-mechanical method of projecting a moving light ray, as with the cathode-ray tube.

Relation of Number of Picture Elements to Brilliance.

With any system of reproduction depending upon a moving ray sweeping over the field of reproduction, the maximum observed brilliance depends not only upon the intensity of the ray but also upon the length of time (within certain limits) that each element is illuminated. Since the illumination time for each picture element is, with conventional systems, reduced as the number of picture elements per second is increased, we must, to retain a given standard of brilliance, increase the attainable illumination in proportion to any increase in the number of picture elements.

If, however, a reliable means of maintaining illumination of the picture element is developed which continues the illumination after the picture signal devoted to each element has ceased, a light source of much lower intensity is required. Suppose a phosphorescent screen were developed which maintained the correct illumination one thousand times as long as the ray is projected upon each area. Then the impulse of one millionth of a second duration comprising the illumination for each element in a 50,000 picture-element signal with 20 repetitions would maintain illumination for 1/1,000 second, or 2 per cent

of total time, as compared with 0.002 per cent without phosphorescence.

Factors Influencing Persistence of Vision.

The degree to which reliance can be placed upon persistence of vision inherent in the eye is the composite of a considerable number of factors, such as the amount of detail present, rate of action involved, brilliance and contrast of projection and room illumination. Motion pictures possess considerable detail, contrast and brilliance and are projected under favorable conditions of low illumination.

Although recognizability is readily obtained with considerably less than optimum conditions, such as those involved in motion-picture reproduction, failure to attain at least that standard inevitably introduces eye fatigue after more than brief observation. Considering the prospective cost of television transmission and reproduction, continued commercial support cannot be expected for any system which causes eye fatigue to its followers. A convenient amount of room illumination must also be tolerated, certainly more than the average existing in a motion-picture theater. The television reproduction must be capable of being viewed clearly with the amount of room darkening readily secured under normal daylight conditions. The probabilities are that such brilliance and contrast will be possible only by means of a powerful local source of projected light subject to the control of the television signal. This requires discarding of the present method of viewing merely the amplified picture signal itself. The Karolus projector, demonstrated by Dr. Alexanderson of the

FORMING THE IMAGE IN REPRODUCTION

General Electric Company is a development in this direction.¹

From the foregoing discussion, it is obvious that we are far from the ultimate form of light reproducer in television. The cruder devices, depending upon illumination of a relatively large plate slightly larger than the field of reproduction and to be observed through a scanning disc, are limited in the number of picture elements which they can accommodate. Other forms of illuminators, more efficient from the energy distribution standpoint, are prohibitively complex and costly. Perhaps the reason that greater progress has not been made in this field is that the simpler means have been adequate for the most complex television devices built to date.

Since we can depend upon so simple and fundamental a phenomenon as discharge of electrons through a vacuum for producing luminosity, the flexibility of these facilities makes it probable that this element of television reproduction will keep pace with progress in other parts of the system. The ease with which an electron stream in a vacuum is controlled at high frequencies and the rapid increase in our knowledge of electron control in a vacuum foreshadow rapid developments and opportunities for the display of inventive ingenuity.

So long as we are confined to small values of light controlled by the picture signal, we must content ourselves with peephole television. This means observation of an image created by projecting light directly to the eye of the observer. When larger sources of light energy are available, the intensity of which can

¹ See pages 120-124.

TELEVISION

be directly controlled by the picture signal, we can then observe a projected image, similar to that made on a motion-picture screen. The only means so far available for producing light as a result of a varying picture signal is dependent upon such relatively feeble devices as the neon tube. Varying the intensity of the primary illumination source by means of electron discharge tubes may not yield a sufficiently powerful light source for screen projection. Dr. Alexanderson some years ago demonstrated the possibilities of television projection if we could project seven intensely powerful sources of light simultaneously throughout their range of illumination by means of seven received picture signals.¹ We are therefore constrained to controlling the projection of a powerful light source of fixed value, as is done with motion-picture projection. But, electromagnetically controlled shutters for accomplishing this purpose appear to be hopelessly slow, being limited to 400 or 500 picture-signal impulses per second at the most. A multiplicity of such light shutters at once leads us to a relatively complex machine which may be suited only to the serving of large audiences paying admission.

Magnifying the Image.

By means of lenses and magnifying mirrors, it is possible to project the reproduced image to a convenient size. It must be remembered, however, that every magnifying glass and prism used tends to reduce the illumination reaching the observer. The most convenient size for a television reproduction is best

¹ E. F. W. Alexanderson, at annual meeting of the *Institute of Radio Engineers*, New York, January 10, 1927.

determined by the number of picture elements, the attainable brightness and the distance of the field of reproduction from the observer's eye.

Figure 68, page 202, shows a form of projector developed by the Jenkins Television Corporation for enlarging a 48-line reproduction. The lens forms an image having about four times the area of the reproduction formed on the plate of the neon tube as viewed at a convenient distance from the eye.

The area of reproduction should never be so small that detail is produced which is not discriminated by the eye. On the other hand, it is preferable that the image be reduced to a size such that normal detail is actually reproduced. In the next chapter, the relation between density of picture elements and correct viewing distance is taken up.

Reproduction of Color Television.

The reproducing system of the Bell Laboratories color television system illustrates the flexibility of optical systems. Instead of a single reproducing light source, the image from three glow tubes is projected to the eye through a semi-transparent mirror, two lenses and a scanning disc. One of the glow tubes is of the familiar neon type, which projects the "red" image. A filter excludes all but the red component of the glowing neon. Two argon tubes, rich in their output of green and blue, contribute those elements of color through suitable filters. Three signals are projected, one for each of the three glow tubes, and the resulting images superimposed for simultaneous exposure to the eye. The writer witnessed a demonstration of this apparatus conducted under the super-

vision of Dr. Herbert E. Ives. The coloring of the subjects was brilliant and realistic without a trace of distortion due to imperfect superimposition of the three images.¹

The successful reproduction of color requires accuracy of a somewhat higher standard than is necessary for black and white images. With the latter, if the light source fluctuates around too high or too low a value, the reproduction is too light or too dark, as the case may be. With color reproduction, however, each of the three light sources must fluctuate about precisely the correct value, or else marked distortion in color will result. Except in those few elements of the scene which correspond in color precisely to that of one of the filters, each patch of color is formed by the combination of the three colors in their correct proportion, and an incorrect blend results in a strikingly unnatural appearance, producing distortions which only a trained eye can analyze. The eye is trained to accommodate itself to a wide range of light intensities, but it cannot readily supply missing color elements. Furthermore, the disintegration of the image into colors, necessitating the projection of beams of colored light, requires light sources of considerably greater total luminosity to equal the effective brilliance of a white light producing a black and white image.

¹ See page 106.

CHAPTER X

SYNCHRONIZATION OF TELEVISION

The conventional television picture signal conveys two kinds of information: (1) the intensity of light reflected from the picture element being scanned at each instant and (2) the relative position of the picture element with respect to the other elements of the field of view. The former information is conveyed by the intensity of the picture signal, the latter by the time relation to the beginning of transmission. Since scanning is conducted along a rigidly maintained pattern and at an accurately established rate, there is a specific instant, a definite interval after the beginning of each frame, assigned to the transmission and reproduction of each elemental area.

Essentials to Faithful Reproduction.

To secure a reproduction accurate enough to permit the reconstruction of the field of view at distant reproducing points without observable variation, the following elements must correspond:

1. The reproducing light source must accurately follow the light intensities reflected to the light-sensitive element at the transmitter.

2. The reproducing scanning disc or corresponding distributing system must follow out the same relative course as the scanning process at the transmission point, describing the same number of lines per scanning

TELEVISION

and bearing the same ratio of width of horizontal line to total height of field of reproduction.

3. The reproducer disc or distributor must revolve at precisely the same rate as the transmitting disc or other scanning means.

4. The reproducer disc must expose or illuminate the elemental area of the field of reproduction corresponding to the area of the field of view being scanned at all times.

Each of these four elements contributing to faithful reproduction depends upon the electrical and mechanical similarity of transmitting and reproducing means. Taking each of these four elements in order, the performance requirements are:

1. Amplification of photocell output, modulation of carrier, transmission through wire or radio channel, amplification, rectification and further amplification at the receiving point and reconversion of picture signal to light must be accomplished without discrimination in favor of or against any of the essential frequency range or, in absence of accurate transmission and reproduction of any part of that frequency range, suitable means of equalizing or correcting such inaccuracy must be provided.

2. Distribution of resultant light intensities in the field of reproduction must be carried on by an electrical or optical system having the same characteristics as the transmitting scanning system; for example, if scanning discs are used both at transmitting and reproducing point, both discs must have the same number and relative arrangement of apertures.

3. The motive power controlling the electrical or optical distribution of the light produced by the

SYNCHRONIZATION OF TELEVISION

picture signal must revolve at the same rate of speed as the corresponding motive power source affecting disintegration of the field of view at the transmission point.

4. The picture element in the field of reproduction controlled by the picture signal must correspond in position to the picture element of the field of view being scanned.

Distinction between Framing and Synchronization.

It is important to distinguish the difference between each of these factors because they involve different parts of the transmitting and reproducing system. For example, the transmitting and receiving system may work in precise harmony as to number and arrangement of apertures, the power source motivating both scanning discs may operate at precisely the same speed and the reproducing light may follow accurately the light variations reflected to the light sensitive element, but inaccurate reproduction may, nevertheless, occur. The transmitting scanning disc may be exposing the top line of the field of view; the receiving disc, on the other hand, may be exposing a line near the center of the field of reproduction. In that case the observer will see the upper half of the field of view on the lower half of his reproducing area, while the lower half of the field of view will appear to him on the upper part of his field of reproduction. Correcting the position of the reproduction in the field is called *framing*. Maintenance of correct rate of distribution in the field of reproduction corresponding to the scanning rate is called *synchronization*.

We have already considered the essentials to faithful transmission and reproduction of picture signal so

that the reproducing light intensity corresponds to the light intensity reflected by the scanning disc to the light sensitive element. Correspondence of the distribution system reconstructing the image at the field of reproduction to the evolutions of the system scanning or disintegrating the field of view requires, obviously, similar scanning discs or signal distributor, both as to number of lines and as to relative proportion of length of line to height of reproduction. It is desirable, as practical television services develop, that standards for numbers of lines and proportions of field of view be agreed upon, in order that reproducers in the hands of the public be adapted to reproduction of television images from any transmitter within range. If such standards are not observed, separate television reproducers will be required for each method of transmission employed.

Effect of Inaccurate Synchronization.

Before considering the various means of maintaining synchronization, it is advantageous to determine the accuracy required and the effect of lack of synchronization of varying magnitudes. The crudest conceivable television capable of reproducing simple objects in very slow motion is one of 20 lines exposed 10 times per second. The scanning disc speed is therefore 600 r.p.m. Suppose the reproducing disc revolves one half of one per cent faster than it should, or 603 r.p.m. The transmitting disc scans 20 lines per revolution or 12,000 lines per minute. In other words, it requires $1/12,000$ minute to scan each line. The reproducing disc also scans 20 lines per revolution, but makes 603 revolutions per minute. Therefore

SYNCHRONIZATION OF TELEVISION

it requires but $1/12,060$ minute to expose a line of the field of reproduction so that it is already advanced in the second line when the transmitting disc begins to scan the second line. With each line, the disparity in the position of the two discs is increased.

The effect of this gain is to shift the framing of the field of reproduction progressively from left to right or right to left (depending on direction of rotation of the scanning disc) at the rate of one complete displacement each 20 seconds. With 20 repetitions per second, instead of 10, the rate of displacement is naturally doubled. Many systems of synchronizing by means of governors or braking systems which have been proposed do not maintain sufficient constancy to keep speed even within the broad limit of one half of one per cent. While an image fading out of frame continually is not a serious matter with an experimenter, it is a sufficient annoyance to a non-technically inclined person seeking television entertainment to make such a system unacceptable.

Accuracy of Synchronism Required.

With a horizontal system of scanning of 50 lines from top to bottom, a representation of a picture element is transmitted each $1/2,500$ of the time required for each repetition. Assuming a repetition rate of 20 per second, each picture element is assigned $1/50,000$ second for transmission. Each element is provided for in systematic order according to the design of the scanning system. With the conventional spiral arrangement of apertures, the fourth picture element of the top row is scanned $3/50,000$ of a second after the first element; the first element of the second

row, $50/50,000$ or $1/1,000$ second after the first element of the frame and the last picture element on the bottom row, $2,499/50,000$ second after the start.

Obviously both the disintegration and the reconstruction of the field of view must be accomplished by an exceedingly stable mechanism which carries out its regular program accurately as to rate and position. The maximum deviation from synchrony which is not automatically corrected by changes in the speed of the reproducer should not exceed the width of half of a single picture element per frame. In the case cited, the scanning disc motor should hold its speed to within 1 part in 5,000 for each revolution. With a 50-hole disc, the holes are spaced 7.2 degrees apart, each picture element being 0.02 of the total sweep per line. The angle represented by a picture element is 0.1440 degree. Since the maximum deviation which can be tolerated is half that angle, synchrony must be within 0.07 degree.

Since the accuracy of synchronization required is a function of the picture elements per revolution of the scanning disc, experience will no doubt establish a definite minimum ratio of synchronizing frequency to maximum picture-signal frequency necessary to hold the reproduction steadily before the observer. When reliance is placed on synchronous motors at both terminals, it appears that the synchronizing signal, however incorporated in the system, requires a frequency which is in the order of 5 per cent of the maximum picture-signal frequency.

Early Attempts at Synchronization.

The first experimental television kits distributed for amateur use depended upon manual speed control for

SYNCHRONIZATION OF TELEVISION

maintaining synchrony. The most popular method was the employment of a fairly constant speed direct-current motor which rotated the scanning disc through a friction clutch. C. Francis Jenkins first described such a system to encourage amateur experimentation. Another system attempted by Pilot's engineers, who

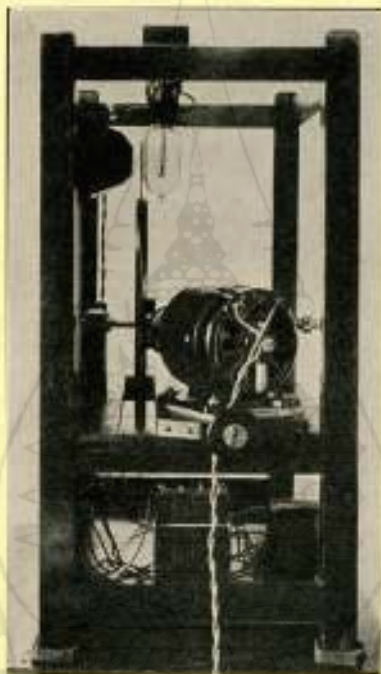

FIG. 57.—Side view of Pilot television reproducer demonstrated in October, 1928. It produced a 48-line image, one and a half inches square.

experimented for some time through WRNY in New York, employed a magnetic clutch arrangement shown in Fig. 58.

TELEVISION

Dr. Alexanderson built a number of television receivers for home use, employing synchronous motors with a resistor connected at the motor terminals through a push button. By skillful manipulation, deviation from synchrony is corrected by allowing the rotor to slip out of "mesh" as the field is weakened with the aid of the resistor. The same principle is



FIG. 38.—One of the first complete television reproducers offered by the Pilot Electric Company in 1929. A magnetic clutch was intended to maintain synchrony.

employed with direct-current motors. While such devices seem to meet the requirements of experimenters, they fall far short of providing care-free entertainment.

Although experience has demonstrated that manual synchronization is a feat calling for an order of dexter-

SYNCHRONIZATION OF TELEVISION

ity and an exhibition of patience beyond the capacity of the average experimenter, reliance on manual methods has persisted. One system after another has been exploited only to be wrecked on the shoals of unsatisfactory synchronization. The hope once reposed in manual synchronization is indicated by the statements issued in connection with Dr. Alexan-

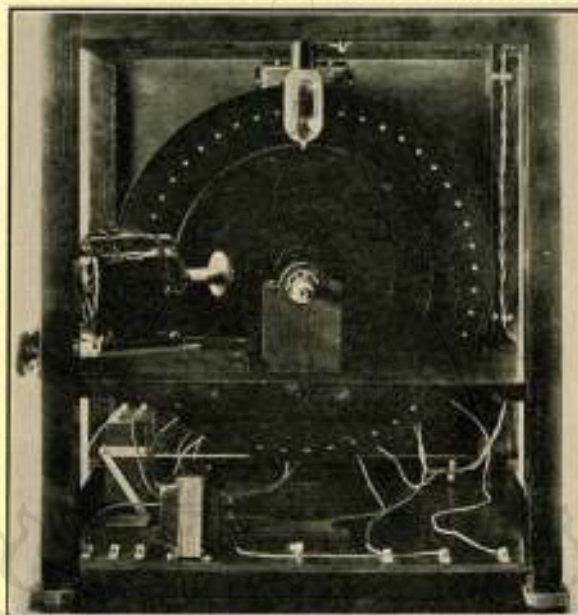

FIG. 59.—Rear view of the Pilot friction-drive television reproducer.

derson's television reproducer when it was demonstrated to the press on January 13, 1928.

Whenever television has been discussed in the past there has always been some pessimist who has wound up the discussion by asking "how are you going to synchronize?" The answer has always been that we will have a synchro-

TELEVISION



FIG. 60.—Dr. E. F. W. Alexanderson and his family viewing a television reproduction in their home. The manual-synchronization control is in Dr. Alexanderson's hand.

SYNCHRONIZATION OF TELEVISION

nous motor and transmit a special synchronizing wave or synchronize to the picture frequency or to a tuning fork. But all these devices mean higher cost, special amplifiers, and more things that may get out of order. We, therefore, simply decided to leave out all this complication. We took a standard electric motor made for household use and are manipulating its speed by an electric hand control. With a little practice and coordination between the eye and the hand, it is possible to hold the picture in the field of vision as easily as one steers his car on the middle of the road. In special cases, when the transmitting and receiving systems are on the same power network, the machines may be operated by 60-cycle synchronous motors.

After describing the facilities for transmitting television signals, Dr. Alexanderson continued: "We feel that the inauguration of this new development will be the starting point of practical and popular television."¹

David Sarnoff, President of the Radio Corporation of America, declared on this occasion,

While this is an historical event, comparable to the early experiments in sound broadcasting, the greatest significance of the present demonstration is in the fact that the radio art has bridged the gap between the laboratory and the home. Television has been demonstrated both in this country and abroad prior to this event, but it did not seem possible within so short a time to so simplify the elaborate and costly apparatus of television reception that the first step might be taken toward the development of television receivers for the home.²

¹ Statement released by Information Bureau, Radio Corporation of America, January 14, 1928.

² Statement released by News Bureau, General Electric Company, January 14, 1928.

TELEVISION

A few months later, representatives of the General Electric Company, testifying before the Federal Radio Commission, stated that no conclusive evidence of regular and successful reproduction of their transmissions had been reported and cessation of the television schedule had been accepted without protest. A more convincing test of the possibilities of popularizing television relying on manual synchronization can hardly be conceived, combining the most distinguished scientific auspices, the finest technical publicity and exploitation organization and an outstanding broadcasting station of considerable power and coverage, all cooperating at a time that public interest in television was at a maximum. But Dr. Alexanderson and his associates have not in the least relaxed their researches and, as we have already seen, are responsible for demonstrating the only fundamentally new method of television reproduction since the neon-glow lamp, for which Dr. D. MacFarlan Moore, also of the General Electric Company, is responsible.

Power-line Synchronization.

The simplest method of synchronization which does not require a special communication channel for transmission of a synchronizing signal is dependence upon the uniform 60-cycle frequency supplied through power lines for driving synchronous motors. In many parts of the country, there is sufficiently widespread interconnection of power lines to provide a reference frequency within the service range of a television station. On the other hand, there are many populous centers served by non-interconnected power services. For example, in the vicinity of New York City, elec-

SYNCHRONIZATION OF TELEVISION

trically independent power systems in Queens, Brooklyn, New Jersey and the direct-current districts of Manhattan do not offer an early possibility of general synchronization through power lines, although the widespread availability of television service would probably force interconnection. The point is frequently made that synchronously driven electric clocks, accurate within a few seconds a day, prove that even non-interconnected systems adhere closely to the standard 60-cycle frequency. However, it is customary to check total cycles every hour or two and to make corrections by running power supply alternators above or below 60 cycles to compensate for deviations which may have occurred. Therefore, while there may be an average of 216,000 alternations every hour, the minute to minute variations may be sufficient in some instances to make television synchronization among non-interconnected systems difficult.

Effect of Voltage and Load on Synchronous Motors.

Utilizing the conventional four-pole synchronous motor, the difficulty of maintaining a stabilized phase relation also complicates the power-line synchronization method. Such a motor, when operating at full load, with a unity power factor, has an angular phase displacement of about 20 electrical degrees between the impressed and back potentials. This corresponds to 10 mechanical degrees, taking into account the fact that the motor has two pairs of poles. If the line voltage varies, the phase angle decreases as the voltage increases and *vice versa*. Likewise, if the load varies, the angle increases as load increases and *vice versa*. These variations, particularly in areas having

industrial loads, are sufficient to introduce serious irregularities in television reproduction. Therefore synchronous motors with many pairs of poles are necessary to maintain constancy of speed between two or more remotely located synchronous motors on the same power circuit.

To maintain a 50-hole scanning disc in satisfactory synchrony, within the limit of half a picture elemental area, requires maintaining the correct position of the scanning disc within 0.07 degree. To indicate how precise a proposition this is, the angular twist of a 1-inch steel shaft 6 feet long operated at rated load is practically that amount. As the number of picture elements increases, the precision required becomes increasingly delicate.

Synchronizing Systems Depending on Photoelectric Cells.

A scheme for synchronizing proposed by Paul L. Clark utilizes a photoelectric cell. The intensity of the neon lamp is controlled by the picture signal and projected to the eye through a form of prismatic disc. A small part of the reproducing light is diverted through a grating of slits to a photoelectric cell. When the motor falls out of synchrony, the light, instead of reaching the cell, is intercepted by the grating, causing a change in the output of the cell, which, duly amplified, weakens the field strength of the motor through a special control field coil, stepping up its speed. There may be a possibility of developing some such system, when neon tubes of illumination sufficient to actuate light-sensitive cells are available. The system, as disclosed, makes no provision for discriminating between reduced illumination due to the light-sensi-

SYNCHRONIZATION OF TELEVISION

tive device caused by non-synchrony and that caused by a dark part of the field of view. If a part of the field of view, for instance, the first picture element of each line, is devoted to synchronization by this means, the gain is questionable, because the same frequency space might be devoted to the transmission of a timing signal for controlling the motor directly without the need for diverting the all too scarce illumination from the field of reproduction. In view of the probable improvement in controlled light sources and light response elements, the general principle of the use of photoelectric synchronizing control depending on the reproduction illumination source may, however, become of practical value in the future.

An inherent difficulty in all systems depending upon correction of deviations from synchrony by mechanical or electrical means is due to their normal cycle of operation. The speed of the device they are intended to govern inclines to "hunt" within the limits of control employed. The higher the frequency of control the narrower these limits and, likewise, the higher the frequency of fluctuation; the fundamental principle is not altered. For example, the tendency of the system may be to permit the motive source to revolve slightly above correct speed and to check that tendency by a remotely controlled means of slowing it down to the correct speed. In actual practice, all such governor systems tend to go through a cycle of overspeed, which is then overchecked; the momentum gathered to build up to correct speed again brings the motor to overspeed, and this cycle tends to maintain itself.

TELEVISION

When the picture signal itself is used for synchronization purposes, difficulty is usually experienced because of the influence of picture-signal variations on the control system. To avoid this the natural tendency is to isolate a small part of the picture elements or field of reproduction illumination in order that it may be devoted exclusively to speed control. This brings us logically to a separate synchronizing signal filtered out from the frequency band devoted to television transmission.

Magnitude of the Synchronization Problem.

Important as is accurate synchronization to reliable television service, comparatively little attention has been given its development up to this time. Many public demonstrations have been made under conditions eliminating this vital factor essential to regular service or utilizing methods which cannot be provided practically for home use. When both scanning motor and reproducing disc are mounted on the same shaft without the intermediary of the communication channel, service conditions are not simulated and the capabilities of the system under service conditions cannot be conclusively determined.

Some television stations are radiating picture signals without any provision for synchronization. Owners of reproducing apparatus are expected to synchronize their equipment by the haphazard process of manual control, a juggling achievement which appeals at first because of its sporting character but sooner or later becomes utterly boring to the most hardened experimenter. Perhaps the only instance in which the synchronizing problem has been fully met in a demon-

SYNCHRONIZATION OF TELEVISION

stration of radio television was in that conducted by the Bell System in 1927 between New York and Whippany, N. J. The apparatus required is fully described in the October, 1927, issue of the *Bell System Technical Journal* and the reader who would pursue this subject in greater detail is advised to make a thorough study of that issue, which includes complete descriptions of all the apparatus used in that demonstration.

The Bell Telephone Laboratory's Synchronizing System.

In order to maintain an accuracy of half a picture element, this system required synchrony within 0.07 degree. A special synchronous motor with 120 pairs of poles was devised, which, with 20 degrees normal full-load displacement, maintained synchrony within $\frac{1}{6}$ degree of mechanical phase displacement. This motor (when supplied with an alternating current of 2,125 cycles) revolves at 1,062.5 revolutions per minute (the product of 17.7, the number of repetitions, multiplied by 60). It is of the variable reluctance type, giving one cycle per tooth. This type was selected because it simplifies the coil arrangement, there being but eight armature coils instead of one for each coil, as required with the usual synchronous motor.

In order to make unnecessary an amplifier system of sufficient output to furnish power for driving a relatively large scanning disc, the amplified 2,125-cycle synchronizing current is used solely for speed-regulation purposes. The major driving power for the scanning disc is secured from a direct-current power having inherently poor regulation, while the

TELEVISION

2,125-cycle synchronous motor is used to maintain accurate synchronization.

Inasmuch as the synchronous motor may interlock in any of 120 positions, all but one of which are out of synchrony, a special 17.7-cycle synchronizing signal is used to establish the position of rotors of the transmitting and reproducing motors in correct angular displacement. This frequency is supplied to the field

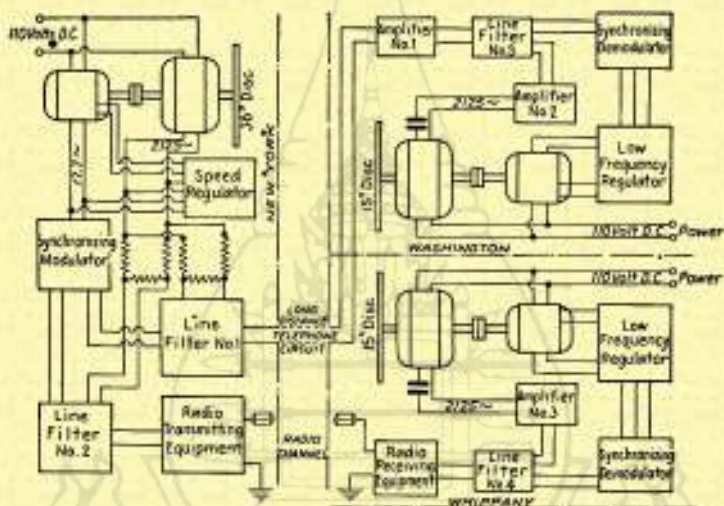

FIG. 64.—Schematic diagram of synchronizing circuits used in the Bell System Washington-New York 50-line radio and wire television demonstration.

through a pair of slip rings tapped to two opposite commutator bars of the direct-current motor. When the two motors have been interlocked by this synchronizing signal, the 2,125 cycle is then thrown in to establish accurate synchrony. Because 17.7-cycle pulses are not readily transmitted through communica-

SYNCHRONIZATION OF TELEVISION

tion channels, it is necessary to cause this frequency to modulate a 760-cycle carrier. Both the 760- and 2,125-cycle synchronizing currents are transmitted through the same communication channel and isolated through suitable filter systems.

While this system of synchronization proved effective during the series of demonstrations conducted, it is obviously complicated and costly. Two synchronizing frequencies are required and two successive operations are necessary before actual synchronization is effected.

The Improved Bell System Synchronizing Method.

For the 72-line television system, first demonstrated in June, 1930, a somewhat simpler synchronizing system was developed.¹ The scanning disc was motivated by a four-pole, compound-wound, direct-current motor, having an auxiliary regulating field, controlled by a vacuum regulator. A special damping winding was developed which permitted the total flux of the motor to increase or decrease as required by the regulating circuit, but which opposed any tendency of the flux to shift back and forth across the pole face. A synchronizing frequency of 1,275 cycles was supplied from a vacuum-tube oscillator, the output of which was made available at both terminals of the system through a special wire line circuit. On the shaft of the direct-current motor was a small pilot generator which delivered 1,275 cycles at the desired speed of operation. The outputs of the control oscillator and of the pilot generator were both coupled to the grids of a push-pull amplifier system which

¹ See pages 39-41, 101, 104-106.

impressed its output on a bank of three regulator tubes. If the controlling frequency and the pilot generator were delivering the same frequency which occurred when synchrony was established, the detector tubes delivered the maximum output to the regulator tubes.

To start the system, the switch was closed, applying three-phase power from the slip rings of the motor to the transformer. As the motor reached the operating point, a beat frequency between the output of the pilot generator and that of the oscillator was set up, observable as a movement of the needle of the meter through which the current passed to the regulating field. When the exact operating speed was obtained, the beat frequency in the regulating field fell to zero. Then when the motor tended to speed up, the phase relationship between the pilot generator and the oscillator reached a point tending to give maximum strength to the regulating field. Further increases in the motor speed were checked by the increased field, so that the speed tended to fall until the phase of the pilot generator with respect to the oscillator had reached the equilibrium value, after which the motor continued to operate at a constant speed.

Instead of obtaining the 1,275-cycle current direct from the transmitting station by wire or radio, it may be supplied from an independent local oscillator of sufficient stability to maintain synchrony between the transmitting and receiving motive systems.

As a further measure to insure stability of rotation of the scanning disc, a hydraulically damped coupling between the motor shaft and the disc was provided, consisting of a flexible metal bellows filled with oil

SYNCHRONIZATION OF TELEVISION

and connected by a small pipe with a needle adjusting valve. This synchronizing system proved remarkably effective, no swinging of the subjects from side to side being observed during the demonstrations. Complex as it appears, the method was a marked simplification over its predecessor.

Short-wave Synchronizing Signal.

Various proposals have been suggested for distributing synchronizing signals on a national scale by means of a standard transmitted through a centrally located short-wave station, so that each television broadcasting service will not be compelled to radiate a special synchronizing signal for those utilizing its programs. So long as such synchronizing signals are received with constant volume, such a reference frequency is prospectively useful. Any marked fluctuation in the signal, however, is reflected in the power delivered to the synchronous motor and this, in turn, affects its phase displacement. Considering the fading and fluctuations experienced with short-wave transmissions, a separate system of synchronizing signal broadcasting is likely to be as extensive as that required for the broadcasting of the picture signals themselves. Since it is a great operating convenience to combine the transmission of television programs with their own synchronizing signals, the latter method rather than national distribution of a reference frequency is likely to be the practice for at least the initial stages of television service.

Because of the varying character of the transmission quality of the ether medium between any two points at different frequencies, it is preferable to utilize a

TELEVISION

frequency for synchronizing purposes as nearly adjacent to the picture-signal frequency as possible. A separate synchronizing band removed from a picture-signal band by any appreciable amount is likely to introduce difficulties which are not readily compensated for because the fluctuations in the transmission quality of the separated frequencies will not carry out the same cycle of variations. A reference frequency of variable amplitude may nevertheless be exceedingly useful in checking the accuracy of an independent synchronizing frequency source.

Independent Sources of Stable Frequencies.

The possibility that a stable source of high-frequency currents for driving synchronous motors can be developed which will eliminate the necessity for remote control has received some attention from authorities in the field. Piezo-crystal oscillators have been built which maintain their frequency to 1 part in 1,000,000, but none so far developed is sufficiently simple in character to show much promise as units in a commercial home receiver to be sold at a reasonable price. The quartz crystals must be accurately ground; their temperature must be accurately maintained to a fraction of a degree centigrade and the power supply to the vacuum tube associated with them must be exceedingly constant. There are so many uses for a constant and accurate source of high-frequency currents that considerable research effort is being expended in this direction. There is always the hope that some day a new and practical method will emerge from the laboratories for setting up high-

SYNCHRONIZATION OF TELEVISION

frequency currents of such stability and accuracy that synchronization in television will become a completed problem.

Judging from the results now being obtained with crystal-controlled vacuum-tube oscillators under laboratory conditions, it should be possible to maintain frequencies constant to 1 part in 10,000,000. It is not possible to adjust the frequency of a crystal oscillator to an absolute value and maintain it to that value within these limits, but two or more independently controlled frequencies may be made to retain their original values within these limits. Two crystal oscillators having nearly the same frequency were set up in the Bell Laboratories so that variations in the low difference frequency could be determined accurately. By the method used, the relative accuracy, assuming one oscillator to be constant, could be determined to 1 part in 500,000,000 during each 5-second interval. Slow variations, having the period of the thermostat operation and amounting to a few parts in a hundred million occurred, but, over a period of 4 hours, the total variation resulting was less than 1 part in 10,000,000.¹ These results were obtained under most exacting laboratory conditions with precise temperature control and under the supervision of experienced engineers. They foreshadow the possibility of stable oscillators of somewhat lower yet adequate standards for television synchronization purposes, which require only initial adjustment at the beginning of the program.

¹ MARRISON, W. A., Frequency Measurements, *Bell Laboratories Record*, Vol. VI, No. 6, August, 1928.

SYNCHRONIZATION OF TELEVISION

The final stage of the tuning-fork amplifier consists of two UX 250 tubes in push-pull arrangement. While this principle has not yet been applied in television, it may be susceptible of development for this more exacting service.

Framing the Image.

For reproduction at the proper position in the field, it is necessary not only to maintain synchrony between transmitting and receiving systems, but also to assure that the reproduction is properly framed.

If we could place the neon-glow tube in any position along the periphery of the scanning disc, rotating in synchrony, we could invariably find one position at which the image is correctly placed in the field of reproduction, so that the outermost hole of the disc exposes the neon tube as the top line of the field of reproduction is being scanned. In all other positions of the neon tube, however, the image would be improperly framed. The top of the scene, for example, might be at the middle, with the bottom just above it, producing an effect occasionally observed in carelessly conducted motion-picture projection.

In practice it is convenient neither to change the position of the neon tube or to observe the image upside down or on its side. The reproduction must not only be correctly framed, but it must be so framed at the top of the scanning disc, where provision is made for convenient observation, sometimes with the aid of a suitably mounted lens. One method which might be used is to shut off the power from the synchronous motor for an instant, so that it would lose just enough speed to slip into the correct position.

Naturally, it would be next to impossible to time this interval so accurately that reliable framing could be accomplished by this method. On the other hand, the method of utilizing a synchronizing pulse corresponding to the picture signal, for placing transmitting and reproducing discs in phase, already described on pages 153-157, has the disadvantage of requiring an extra synchronizing signal, a special starting operation and considerable apparatus at both terminals.

Fortunately, a practical manual system of great simplicity is available which has been widely used by many experimenters. Instead of revolving the light source around the periphery of the scanning disc to find the position of correct framing, the frame of the motor is mounted in a helical gear, so that the entire motor can be revolved into any position by means of a worm gear meshing with the helical gear. The scanning disc continues to revolve in synchrony while the framing adjustment is made.

This chapter concludes the description of some of the principal instrumentalities of television as they have been developed up to this time. Many of them now universally used are doomed to discard; others, perhaps the least conspicuous, will expand in utility; finally, new devices and methods will come forward to displace the weak links in the system. But fundamentally, television is bound to retain, in one form or another, the basic elements of the systems described. The field of view must be disintegrated by a scanning process so that it may be reduced to an electric counterpart by a light-sensitive system, or as many light-sensitive systems as there are parallel communication channels to be used; the scanning process must be

SYNCHRONIZATION OF TELEVISION

carried on with sufficient rapidity to give a smooth reproduction of subjects in motion; the resulting signal or signals must then be impressed on the radio transmission system, to be picked up by an antenna system and associated receiving apparatus, restoring it to

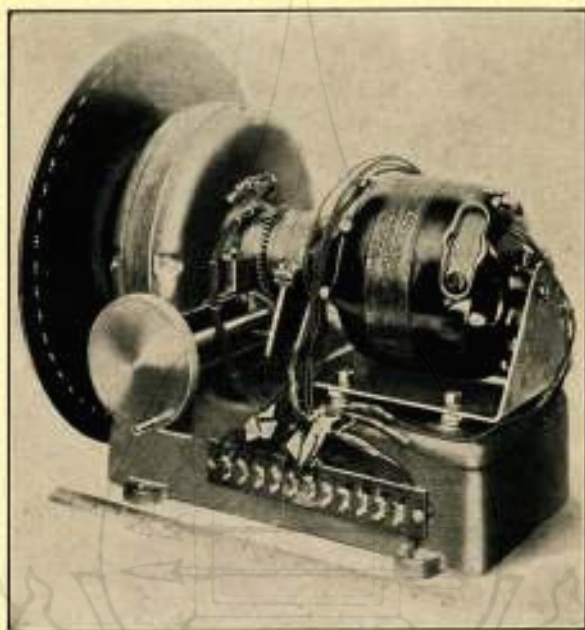

FIG. 65.—The 2,125-cycle synchronous motor, with 120 pairs of poles, used to drive the reproducing scanning disc. The worm drive is used to adjust framing.

electrical form; the counterpart of the original picture signal or signals must control a light source for projection or observation; and the scanning process must be reversed to restore the original arrangement of light impressions.

TELEVISION

The final reproduction is the ultimate purpose of the entire process. The impression which that reproduction makes upon the observer is clearly a function of the visual system. Therefore, the information which the eye requires to discern the elements of a scene without conscious effort or strain must now be analyzed.



CHAPTER XI

THE EYE AS AN INSTRUMENT OF TELEVISION

The human eye, the instrument of vision, consists essentially of an adjustable lens system which focuses an image of the field of view on the retina. Disposed on the surface of the retina are a vast number of light-sensitive elements called rods and cones. The lens system of the eye is quite similar to that of a photographic camera, having means both of adjusting the focus to adapt it to fields of varying depth and of increasing or decreasing the aperture according to the available illumination. In place of a photographic film which makes a single permanent impression of the image focused upon it, the photoelectric elements of the eye form a continuous communication circuit with the brain by means of a separate nerve communication channel for each rod and cone. The eye is, therefore, quite similar to a television transmission apparatus except that it requires no scanning device because there is always available for each picture element a complete communication system to maintain a continuous contact with the brain.

Adjustments of the Eye.

The eye is capable of a considerable variety of adjustments which are being made almost continuously

TELEVISION

without conscious control. The muscles of the lens system focus the eye according to the extent of the field of view being observed and its distance from the eye. The iris controls the size of the aperture according to conditions of illumination, protecting it from excessive light or admitting every feeble ray within range. The muscles of the eyeball, sometimes assisted by the neck, control the direction which is viewed. The six extrinsic muscles rotating the eyeball are the most active and responsive muscles of the human system. The field of view to which the eye responds extends more than 90 degrees outward, 70 degrees downward, 60 degrees inward and 50 degrees upward. The two eyes combined, therefore, have a field of nearly 200 degrees in extent horizontally and 120 degrees vertically.¹ The eye is highly sensitive to motion in this extensive field, although it perceives practically no detail or color, except for a restricted angle near the center of the field. Mechanically the eye is most remarkable, but optically it is deficient in many ways.

Viewing a Television Reproduction.

With so extensive a range of possible adjustments of focus, admitted illumination, sensitivity and direction, it is of interest to determine what adjustment the eye assumes when viewing a television reproduction. Naturally it receives the most concentrated attention of the eye which, therefore, positions the eyeball so that the image of the television reproduction is formed on the most sensitive part of the retina, known as the

¹ Coss, P. W., *Physiological Optics*, "Illuminating Engineering," John Wiley & Sons, Inc., 1928.

fovea. Here the eye is sensitive both to the maximum detail and to the finest discriminations of color.

Regardless of whether the television reproduction is viewed a few inches from the eye through a peephole device or projected on an extensive screen, it is subjected to the most exacting scrutiny of which the eye is capable. When viewing a screen projection, the extent of the image may be too large to be comprehended in its entirety without progressive exploration by the aid of the extrinsic muscles. In that case, the eye selects that part of the field of reproduction of the greatest interest at the moment and subjects it to the most exacting scrutiny, within the limits of the resolving power and sensitivity of the visual system. Apparently the television reproduction must meet most exacting requirements if the eye is not to be conscious of defects.

Color of Reproduction.

The sensitivity of the eye to color varies with the intensity of illumination. If the entire spectrum of colors is observed under very weak illumination, no color can be discriminated. The spectrum under such conditions appears gray, but varies in brightness, being brightest at 0.53μ ,¹ corresponding to green. As illumination is increased, the eye becomes rapidly adapted and the brightest part of the spectrum is then at 0.58μ ¹ in the yellow. This indicates that a screen or field of reproduction feebly illuminated by a green light source will appear brighter to the eye than if any other part of the range of light frequencies is

¹ See page 59.

TELEVISION

utilized. This phenomenon has not yet been used to advantage in any television reproduction system.

If green or blue light is gradually increased in intensity from zero, there is a considerable interval before the color can be discriminated. This is called the photochromatic interval. With red light, the photochromatic interval is practically non-existent. Consequently a field of reproduction illuminated by a neon-glow lamp appears red if it is perceived at all. On the other hand, if the light source were a feeble green, the eye would not be conscious of the color. Since red is a rather unnatural color for most scenes, it is unfortunate that the neon-glow lamp gives rise to red rather than to green, because the observer would not be conscious of an unnatural color in a feeble green reproduction. While glow tubes giving rise to green and other colors are available they require considerably more power to produce a given brilliance than the neon type.

Extensive experiments with flickering images indicate that color does not affect the duration of persistence of vision. Therefore, selection of the most favorable color frequency from the standpoint of sensitivity and contrast does not affect favorably or unfavorably the phenomenon of persistence, upon which the collation of picture elements into a single image depends.

Brilliance of Reproduction.

In view of the difficulties of securing adequate illumination of the reproduction, the television image is most favorably viewed in total darkness. Under

EYE AS AN INSTRUMENT OF TELEVISION

such conditions the iris gradually relaxes so as to admit the greatest possible amount of light.

The light-sensitive elements on the retina are described as rods and cones. It is believed that the cones are excited only by bright illumination, while the rods are the sensitive elements used for observation at low intensities. Twilight or night vision, presumed to be accomplished by the rods, is known as "scotopic" vision. Everyone has noticed the feeling of temporary blindness experienced on entering a motion-picture theater. At first it is difficult to find one's way about or to recognize objects until the eye has adapted itself to the conditions of night or scotopic vision. After 5 or 10 minutes in darkness the eye has become quite well adjusted, but does not reach its maximum sensitivity until some 30 or 40 minutes in comparative darkness. When the eye has fully adapted scotopic vision, it is 1,500 to 8,000 times more sensitive than in full daylight. The contrast required for a good television reproduction viewed in conditions of approximate darkness is therefore small.

The sensitivity of the eye to contrast varies under different conditions, detecting a minimum change in relative contrast of from 0.5 to 1.7 per cent. The least difference in brightness which can be perceived is not a fixed quantity, but is more nearly a constant fraction of the brightness itself. Under average conditions contrast of 1 per cent is just sufficient to be perceivable; that is, two areas varying in brilliancy by a ratio of 1:1.01 will appear as just different. This corresponds to the decibel in measurement of sound. The contrast sensitivity of the eye is reduced if the

TELEVISION

areas compared are seen on a background much brighter than themselves or if relatively large light flux reaches the eye from any direction within its field of view.

A reproduction can be analyzed to determine the range of contrast required for realistic representation. A silhouette is reproduced by only two shades, which, to be barely discernible, need only vary by 1 per cent in intensity. The other extreme is the availability of the entire range from black to white, offering approximately 100 to 200 discernible shades, according to the maximum brightness. Clearly a much more satisfactory reproduction, as far as shading is concerned, can be secured merely by improving the maximum brilliance attainable from the reproducing light source, even though no new detail is imparted to the original picture signal. The feeble illumination so far used in television reproduction obviously fails to portray to advantage the degrees of shading embodied in television signals of the order now employed. Any judgments made on the service value of television are therefore subject to modification when more effective methods of illuminating the reproduction are evolved.

Either contributing toward or furnishing the reason for clearer distinction of contrast when viewing a brilliant reproduction is the fact that the iris reduces in diameter according to the brilliancy of the field observed. If the aperture admitting light to the retina is reduced, the image is sharpened, exactly in the same way that the greatest detail is obtained with a camera by reducing the diaphragm opening. With a large opening of the iris, occurring under conditions of feeble illumination, a point in the field of view is

diffused on the retina over a relatively large area, blurring the detail of the image. Obviously there is a substantial gain in sharpness and contrast as the brilliancy increases in viewing a given field of reproduction composed of a given number of picture elements.

Interfering Illumination.

A factor influencing the responsiveness of the eye to small contrasts is the interfering influence of neighboring illumination. The eye, as has been said above, is sensitive to light over a range extending 200 degrees horizontally and 120 degrees vertically, although its concentrated attention is focused only upon a small conical space directly before it. The presence of a relatively powerful light source within this broad angle of response at once increases the brightness and contrast necessary to secure a discernible image in the center of the field of view.

While it is possible to darken a room to a certain degree without inconvenience, there are practical limits to such darkening. If the television performance is to be continuous and available without interfering with other activities in the home, then a fair amount of general room illumination must be tolerated. In a motion-picture theater, the minimum illumination generally considered satisfactory is one-tenth of a foot-candle while the film is being shown, and the preferred practice in modern theaters is to provide at least five times this value of illumination intensity. If one member of the family watches a television reproduction as others are occupied with different pursuits, a minimum of one foot-candle of general room illumination is necessary for comfort and safety.

At the same time, the difficulty of darkening an average room to one foot-candle or less during bright daylight hours must also be taken into account, because the most attractive television programs, such as sporting and news events, will be available principally during daylight hours. The amount of interfering light with projected television is likely to be fairly substantial, making quite brilliant reproduction essential.

One simple method of disposing of any problem of surrounding illumination is to provide a peephole arrangement which obscures from the observer's eye all light except that from the television reproduction. Such arrangements introduce two problems which tend to counteract the advantage gained. First, unless the arrangement is exceedingly bulky, the reproduction is at a distance from the eye such that it is most perceptive of minute detail, and, therefore, most critical to defects. Second, the observer is forced to attempt to enjoy his television reproduction in a rigidly fixed position, not only of the head and body, but more particularly of the eye itself, which becomes rapidly fatigued if vision is concentrated upon the same part of the retina continuously.

Advantages Gained by Projection.

All of these factors make the conclusion inescapable that projected television, even though the screen area be small, is a minimum requirement to general home service. This at once makes us subject to the interfering influences of general room illumination, and in turn requires considerable contrast and brightness in the field of reproduction. The average

EYE AS AN INSTRUMENT OF TELEVISION

16-millimeter home projector uses a 200-watt incandescent lamp directing a ray of 50 to 60 lumens to the surface of the screen. The picture width is about 4 feet and the throw about 20. If the illuminating source were withheld from the motion-picture screen for an average time as short as would be encountered for a television system of 100,000 picture elements, the power of the light source would have to be one of immense magnitude.

The effect of projection is to increase the dimensions of the field of reproduction. The actual size of the field so far as the eye is concerned is not measured by its physical dimensions, but by the angle formed by its extreme dimensions with the eye. From the standpoint of visual effectiveness, an image may be greatly increased in size without reducing its realism, provided the observer moves proportionately far away and the proper amount of illumination is maintained. So long as the overall angle which the eye must explore to view the whole field is suitably limited, the entire field may be comprehended by a single observation.

How the Eye Explores a Scene.

In practice, the eye prefers a field of reproduction sufficiently large to enable it to roam so as to introduce the proper rest periods to different areas of the retina. Even in such an apparently restrictive operation as reading, the eye obtains its necessary periods of rest. Concentrated attention is restricted to a small area. The eye in reading a single line jumps to four or five positions and rests at each for from $\frac{1}{10}$ to $\frac{1}{4}$ second according to the speed of the

reader. In other words, the eye assumes a rapid succession of fixed positions, requiring not more than $\frac{1}{1000}$ second to make the changes from one to the next, and it rests in each position only a fractional part of a second.¹ Yet each such change is resting a part of the highly sensitive and responsive fovea.

It appears then that we do not view a scene in a motion picture in a complete comprehensive sweep, but rather take a series of impressions over a relatively constricted area. The eye naturally focuses its attention upon the element of the scene where the crucial action which is of the greatest interest to the observer is taking place. For example, anyone having presented to him an airplane view of his home town will almost automatically select familiar landmarks and will attempt to identify his own residence as viewed from above. This concentration upon small parts of a comprehensive field establishes exacting requirements for the detail which must be present throughout the reproduction so that the observer may select any part of it for his attention at any instant with complete satisfaction.

Entire Field Must Possess Good Detail.

The selective properties possessed by the eye can not be conveniently transferred to the television scanning or reproducing system. So as to simplify the communication system required, it is conceivable that high-quality scanning might be restricted to a small area at the center of the field where the most intense action takes place. Imagine an observer in a plane looking at a vast field of view below him

¹See footnote p. 166.

through a powerful spyglass which limits his observation to one spot in the field of view. He may sweep the spyglass throughout this field according to his desire for information, but unless he could precede his selective operation by a comprehensive glance at the whole field, he would be likely neither to find the points of special interest to him nor to secure a comprehensive understanding of the relation of the various parts of the scene which he is able to observe.

Suppose a television scanning apparatus were substituted in place of the spyglass. The reproduction would then consist only of the area selected with the spyglass scanning system. Considerable detail could be conveyed to the observer without an excessive use of the channel facilities, but he would not be able to form a vision of the whole scene as a single unit. It appears then that, in order that the eye may enjoy its habitually employed selective powers, satisfactory high-quality portrayal of scenes through television means a communication system even more comprehensive than that possessed by the eye itself.

Eye Response to Motion.

The eye cooperates very favorably to encourage appreciation of contrast when motion is portrayed in the reproduction. If the eye is focused on a white spot in a black field and the white spot is then removed, that area actually appears blacker to the eye. The eye, being accustomed to lagging behind major alterations in shading, tolerates sluggish operation of a television reproducer in portraying a scene in which black and white are shifting rapidly. Furthermore, the eye is extremely sensitive to changes

in a scene, observing them more acutely than stationary elements. A person can be seen moving, "out of the corner of the eye," even though the eye discriminates nothing of the stationary elements of that part of a scene. The existence of active motion in a scene commands the concentrated attention of the eye, to the detriment of the stationary elements of the field. When motion ceases, the eye tends to review or refresh its memory with respect to the stationary elements, which it has temporarily neglected so as to concentrate on the motion. A blurring of the detail in the stationary elements of a field while following a rapidly moving figure or object, may escape unobserved, particularly if detail is restored when the motion ceases. The allowable distortion of a field involving rapid motion is therefore greater than one of stationary character.

Persistence of Vision.

The most familiar characteristic of vision is persistence. Without reliance upon persistence of vision, there could be no television and no motion pictures. An impression directed to the retina is impressed upon the consciousness some time after the source of the impression is removed. The duration of persistence is influenced by the brilliance and the duration of the originating impression and by the presence of interfering light. There is no magical quantity, such as $\frac{1}{16}$ second, which has been popularly assumed as the precise duration of persistence of vision. Prior to the advent of sound motion pictures, the standard rate of filming was 16 per second, but reproduction was carried on at almost

any speed ranging from 20 to 24 frames per second, the former if the program was ahead of schedule and the latter if the management was cramped for time. Naturally, the action in the film is a bit hasty if the higher speed is maintained, but only then is the observer conscious of any variation in the reliance placed upon his persistence of vision. With sound-on-film, overspeeding produces a substantial rise in pitch of the accompanying sound, with the result that standard speeds of reproduction are more closely adhered to. Sixteen frames per second is the minimum which makes the observer unconscious of the interval between frames and, with the order of illumination and brilliance obtaining in motion-picture reproduction, gives a smooth blend of successive frames. A different quality and intensity of illumination would call for a different optimum repetition rate.

In a general way, an image formed on the retina persists $\frac{1}{30}$ to $\frac{1}{50}$ second. If the brilliance and duration of the original image is such that persistence is only $\frac{1}{50}$ second, 25 repetitions is the minimum which gives the impression of smooth motion; on the other hand, under suitable conditions, 15 repetitions would be sufficient with a bright image, each element of which remains illuminated for a major part of the interval between frames.

If we assume a brilliance of reproduction and duration of originating impression such that maximum reliance can be placed on persistence of vision, the minimum repetition rate giving smooth motion is determined by the rate of the action in the scene. Persons in ordinary controlled motion and views

from a slow-moving vehicle would be satisfactorily reproduced with the aid of a picture signal representing the slowest repetition rate, that is, 15 per second. But rapidly moving figures, such as are involved in athletic sports or scenes taken from a high-speed vehicle, require a higher repetition rate.

On the other hand, the briefer the period each element is presented to the eye, the greater the brilliance necessary to produce an impression. Conversely, as the speed of motion is reduced, the necessity for rapid scanning falls off, up to the point where the whole mass of picture elements constituting one reproduction can no longer be collated as a single image through persistence of vision. Considering the slow-motion subjects so far presented for television programs, the use of higher repetition rates than the minimum required by the eye is induced by inadequate brilliance of reproduction and short duration of originating image rather than by any inherent inability of the eye to form a smooth succession of images from the reproduction.

The ease with which an object is perceived is influenced by its size as measured by the angle which its extreme dimensions present to the eye. The ease of perception increases from the minimum angle discerned by the eye up to two degrees, beyond which no further increase in ease of perception takes place, because the eye begins to explore the elements of a larger object. There is a reciprocal relation among the size of the object viewed, the time of exposure, and the brightness, which determines the ease of perception. Any reduction in one of these three features must be accompanied by a correspond-

ing increase of one of the others up to certain limits to secure equally good perception.

When portraying a scene in which there is no motion, the comprehension of each reproduction improves proportionately to the length of time that the reproduction endures. Leisurely examination permits exploration for desired detail, which is not indulged in when the eye is supplied with subjects of interest by reason of their motion. When the activity of the subject is a routine operation, readily taken for granted, such as speaking and singing, the motion is not of an arresting character and the eye therefore calls for more detail. It should be clear then, particularly in view of the further investigation of detail in the succeeding chapter, that detail requirements vary greatly according to the subject matter.

Necessary Detail in Television Reproduction.

The amount of detail necessary to an enjoyable television reproduction of a scene of given character is a matter which seems to vary according to the optimism of the observer. The foregoing explanation of the characteristics of visual response indicates that no fixed formula can be established which describes quantitatively exactly the detail necessary to a perfect illusion in a reproduction. The brilliance of the reproduction, the amount of interfering light and the amount and character of the action in the scene materially alter the requirements as defined by number of picture elements per reproduction. The psychological influence of accompanying music and vivid speech also modifies any requirements which

TELEVISION

may be set up. Ingeniously planned visual features will take the fullest advantage of the psychological responses of the observer. The more clearly the ear is satisfied by the information delivered to the brain through that channel of communication, the less exacting are the demands of the eye. Dreamy music suggests an indefinite reproduction, while a lecture describing and depending upon elements in a scene which are not reproduced emphasizes the shortcomings of television. Nevertheless, it is of advantage to analyze the resolving powers of the eye because they give one measure, though only one, of several determinants of the information which must be communicated to the eye of the television observer.

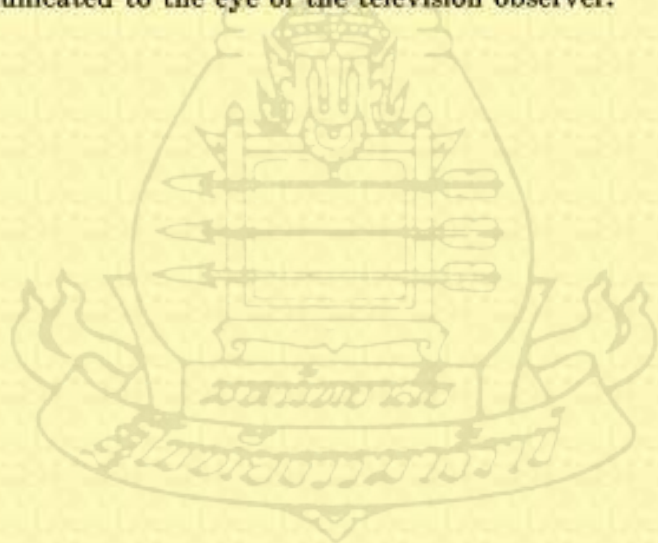

CHAPTER XII

DETAIL REQUIREMENTS OF TELEVISION REPRODUCTION

The term *detail* is used in television parlance to describe the degree to which a reproduction reveals the fine particulars and small elements of the scene which it represents. *Quality* has a broader meaning, designating the composite of all the factors, such as detail, brilliance, contrast and size, which contribute to the fidelity of the reproduction and the realism of the illusion created.

Satisfying the Information Requirements of the Brain.

Detail is defined by the smallest element of a scene which can be discriminated as a definite identity by the eye. If the angle formed by drawing two imaginary lines from the extremities of any object to the retina of the observer is larger than the resolving angle of the eye, the detail can be discriminated, provided the illumination is sufficient. The closer one moves to an object, the larger the angle formed by two lines reaching from its extremities to the retina. When an object in which the observer is interested is not clearly distinguishable, he instinctively moves closer to it, in order that he may enjoy as much detail as the information requirements of his brain demand. He is rewarded with more detail until he is within ten inches of the object. Closer

than this, distortion is introduced by reason of the sharp angle formed from the object to the retina.

So that more detail can be discriminated, we have developed means of "fanning out" the light rays reflected from an object so that finer elements of which it is composed exceed the resolving angle of the eye. The microscope is such a device. With natural objects we can spread out or enlarge the image which an object forms on the retina of the eye up to the point where each source of a light wave forms an angle to the neighboring wave which is less than the resolving angle of the eye. This point is the limit of magnification of the microscope. If greater detail is to be observed, rays having a wavelength shorter than light waves must be used. X-ray analysis, which has enabled physicists to establish the arrangement of electrons within the atom, depends precisely upon this phenomenon.

Conversely, when viewing an extensive scene, we tend to move away from it until all the elements composing it are conveniently observed simultaneously. When we are interested in the relationship of objects, one to the other, we would rather move to such a distance that all of them may be observed at the same time. If it is physically impossible to station ourselves at such a distance, we draw a map or chart so as to bring all the essential elements of the scene within the limits of simultaneous observation.

Requirements of the Eye Are Definite.

All of this leads to a fundamental conclusion: *For a given subject, there is an amount of detail which satisfies the information requirements of the brain.*

DETAIL REQUIREMENTS OF TELEVISION

The detail required is dictated by the subject. If the demand for detail is not satisfied, we tend instinctively to alter our position with relation to the object so that the required detail is observed.

When we are indulging in more than casual observation, as, for example, visiting an art gallery, we willingly go to considerable effort to secure satisfaction of the information requirements of the eye. We move closer to enjoy the precise detail of a Dutch master, and further away to sense the comprehensiveness embodied in the work of a modern landscape painter. Apparently the information requirements of the eye are definitely dictated and must be satisfied if the attention is to be held. Since television is designed primarily for satisfying the visual sense and not merely for casual observation, we are quickly conscious of any lack of satisfaction of the information requirements of the eye.

Detail in a Reproduction.

When viewing a natural object, we can usually observe it as closely as we desire within the limits of the optical capacities of the eye. When viewing a representation or reproduction such as a painting, a photograph or a motion picture, we are, however, limited to observation of the actual detail embodied in the reproduction. For example, a designer of fine hardware may look at paintings in a gallery in order to find suggestions from the craftsmen of the middle ages. He may see a painting of a Venetian doorway. Enthusiastically, he takes a notebook out of his pocket, moves close to it and sketches such

details as he desires. By moving close to the painting he has satisfied his information requirements. At another point in the gallery, he sees a painting of the ancient *Hôtel de Ville* in Bruges. Again he hopes to obtain a suggestion. He examines the painting closely, but the door hinges, in this case, are merely a tiny stroke of the artist's brush. He takes a small magnifying glass from his pocket, but finds that instead of fine detail, enlargement merely shows the ridges and depressions formed by the brush. *No amount of magnification of a reproduction will impart detail which is not embodied in it.*

Establishing the Requirements for Television.

The principles of detail and enlargement which have been discussed control the following questions respecting television reproduction:

1. What is the minimum detail necessary to secure a satisfying reproduction of subjects of various kinds?

2. What is the correct viewing distance for a reproduction of a given size composed of a given number of picture elements?

3. To what extent may a reproduction of given detail be enlarged to advantage?

The detail embodied in a television reproduction of adequate brilliance and contrast is directly proportional to the number of picture elements. The size to which a reproduction of a given number of picture elements may be enlarged is determined by the angle formed by imaginary lines drawn from the extremities of each picture element to the eye.

DETAIL REQUIREMENTS OF TELEVISION

Resolving Power of the Eye.

One method of estimating the requirements in picture elements per field of reproduction for commercial television of the highest useful quality is to use the resolving power of the eye as the basis of calculation. The resolving power of the eye, as we have seen, is the minimum angle by which two points may be separated without losing their identity as two separate points. The resolving power of the eye is therefore a measure of the maximum useful detail with which a reproduction may be endowed.

A television reproduction having a wealth of detail such that each picture element has a dimension so much smaller than can be discerned within the limitations of the resolving power of the eye cannot be improved upon by increasing the density of the picture elements. Since the resolving power of the eye is a measure of an angle, the maximum dimensions of a picture element giving the highest quality of detail which the eye can take advantage of can be determined if the distance of the plane of the field of reproduction from the observer's eye is known. Considering that this reproduction will possess perfection of detail, it may be quite small and still portray subjects of considerable complexity successfully.

A field of reproduction 9 by 12 inches viewed at a distance of 6 feet would make a small but clear reproduction of both indoor and outdoor scenes fully capable of holding sustained interest, provided illumination and contrast were adequate. This dimension is, of course, considerably smaller than the 4-foot width to which 16 millimeter home motion

pictures are usually projected, but two prize fighters in a ring or even a football game clearly reproduced to this size could hold a fascinated television audience.

The resolving power of the eye is by no means an arbitrary or fixed angle. It is influenced by such factors as the diameter of the pupil, the brightness level to which the retina is adapted, the illumination intensity and the contrast of the subject. I am indebted to Lloyd A. Jones of the Physics Department of the Eastman Kodak Research Laboratories for the conclusion that a fair average value for the resolving power of the eye under the conditions under which motion pictures or television reproductions are viewed is 60 seconds of an arc. The resolving power of the eye ranges from 35 to 75 seconds, but extensive researches in the Eastman Kodak Laboratories have established 1 minute of an arc as a fair average value for the resolving power of the eye under the conditions of brightness, contrast and visual adaptation obtaining with artificial reproduction.

In sweeping across a path 12 inches in length at a distance of 6 feet from the eye, the angle covered is 9 degrees 28 minutes, which at 1 minute per element requires 568 picture elements per line for the field of reproduction proposed. Since the height of the reproduction is three-fourths its width, the number of lines is 426. Hence a total of approximately 245,000 picture elements is required to produce a field of reproduction of perfect texture. With twenty repetitions per second, the frequency band required with double side-band transmission is 2,450,000 cycles, assuming our conventional methods of continuous progressive scanning.

DETAIL REQUIREMENTS OF TELEVISION

The quality of reproduction with this texture and with the dimensions and distance from the observer cited is theoretically perfect, no improvement in detail being attainable either by increasing the density of picture elements or by having the observer move closer to the field of reproduction. The

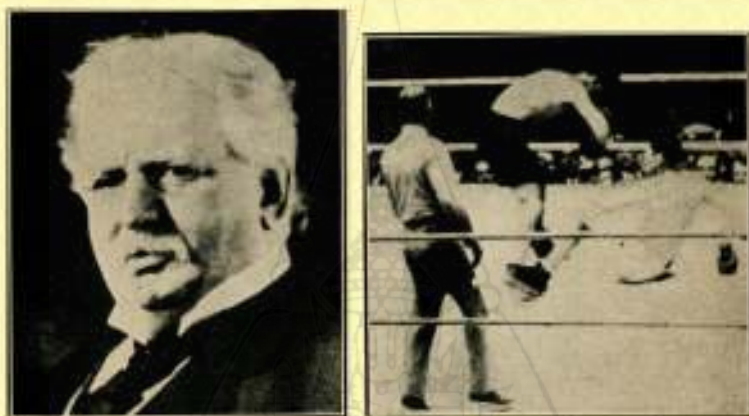

FIG. 64.—A telephotograph consisting of 250,000 picture elements, or approximately the definition of a 500-line television reproduction. (Courtesy of Bell Telephone Laboratories.)

conditions suggested are therefore quite practical, the optimum distance for perfect quality being sufficient to permit a family group to view the television reproduction, at the same time permitting increase of the size of the reproduction either by moving closer to it or by projecting it to a larger size, with proportionate loss of detail.

Peephole Television Requires as Much Detail as Projected Television.

For "peephole" television, suited only to observation by one individual—the equivalent of headphone

TELEVISION

reception of broadcasting—perhaps the best value to select is with the field of reproduction 10 inches from the eye. This is the approximate distance at which the average eye observes the greatest detail. If the field of reproduction is 4 by 5 inches, the eye is capable of observing a scene of considerable wealth of detail and discerning items constituting but a small proportion of the whole field of reproduction. Fully as much information is imparted to the eye with such a reproduction system as by the finest quality of rotogravure printing.

In sweeping across a distance of 5 inches in a plane 10 inches from the eye, the angle traversed is 26 degrees 34 minutes, requiring 1,594 picture elements per line. The height of the field of reproduction requires 1,308 lines, making an approximate total of 2,080,000 picture elements for a reproduction of perfect texture. This is nearly ten times 245,000, the number required by the 9 by 12-inch reproduction to be viewed at a distance of 6 feet. Obviously, the reduction in dimension is not sufficient to compensate for the added density of picture elements made necessary by the reduction of the distance at which the reproduction has been placed from the eye. This calculation leads us to the conclusion that so far as channel requirements are concerned, projected television is less difficult of accomplishment than high quality peephole television.

If, however, we content ourselves with a reproduction $\frac{3}{4}$ by 1 inch, the dimensions of the familiar motion-picture film negative, to be viewed 10 inches from the eye, the reduced area results in a marked conservation of communication requirements. For

DETAIL REQUIREMENTS OF TELEVISION

perfect texture, we require 257 lines, each consisting of 342 picture elements, or a total number of 87,894 per field of reproduction. At 20 repetitions per second, a 900 kilocycle channel is required for the transmission of the resulting picture signal.

The following table shows the dimensions of reproduction to which an image consisting of 87,894 picture elements may be enlarged to retain theoretically perfect texture at various distances from the observer:

THEORETICAL PROJECTION SIZES FOR PERFECT TEXTURE
87,894 Picture Elements

Distance from Eye	Dimensions of Projection, Inches
10 inches	0.75 by 1.0
2 feet	1.8 by 2.4
4 feet	3.6 by 4.8
6 feet	5.4 by 7.2
8 feet	7.2 by 9.6
10 feet	9.0 by 12.0
20 feet	18.0 by 24.0
40 feet	36.0 by 48.0
80 feet	72.0 by 96.0
100 feet	90.0 by 120.0

Mere Enlargement of Present Systems of Limited Possibilities.

The claim is often made that, the principles of television having been demonstrated successfully with a system involving relatively few picture elements, it requires merely improvement of the system to bring it up to commercial entertainment requirements. Logical as this reasoning is, the full significance of the problems involved in such improvement is not appreciated without calculations such as

TELEVISION

the foregoing. The successful accomplishment of a reproduction $\frac{3}{4}$ by 1 inch is too readily accepted as proof that the image can be increased to 4 by 5 inches without changing the viewing distance, for example, by reasonable increase in the size and capacity of the apparatus involved.

A better index to the problem is secured by comparing the maximum picture-signal frequencies involved. The 87,894 picture elements forming a $\frac{3}{4}$ by 1-inch reproduction, which would certainly be considered no more than an interesting demonstration by the public, require a channel facility of 900 kilocycles for 20 repetitions; to increase the size of reproduction to 4 by 5 inches without reducing density is a matter of somewhat more than twentyfolding the capacity of the apparatus; it calls for a system of terminal and channel equipment capable of handling some 2,340,000 picture elements, presenting a problem of about 250 times the magnitude of the first.

Two hundred and fiftyfolding the speed of any process, particularly one involving such delicate accuracy as television, is not to be considered without the deference which is its due. Automotive engineers, for example, do not hesitate to build racing automobiles capable of speeding 150 miles an hour, but they hardly consider an order to build a car to travel 250 times as fast, as a reasonable demand. It is no more likely that such a speed will be attained by merely increasing the power, speed, or dimensions of a motor vehicle built along present-day conventional lines than that a high-quality commercial television reproducer of 1,000,000 picture elements per frame will be perfected merely by detailed improvements of

DETAIL REQUIREMENTS OF TELEVISION



FIG. 65.—The pictures on the left are the equivalent of what could be transmitted over ten broadcast channels; those at the right, over twenty. (Courtesy of Bell Telephone Laboratories.)

TELEVISION

established instruments and methods. Fundamentally new principles must be applied, involving ingenuity of a far higher order than is required for mere enlargement or general speeding up, or else the hope of large reproductions of perfect texture must be abandoned.

Picture Elements in Motion Picture.

A motion picture viewed in a theater at a distance of 50 feet is an example of commercial reproduction of high quality. The usual dimensions of such a screen are 18 by 24 feet. Based on the resolving power of the eye at a distance of 50 feet, perfect texture is secured with approximately 1,800,000 picture elements, a number smaller than is required for the 4 by 5 peephole television system of maximum useful quality. The chemical processes which contribute to the making of the $\frac{3}{4}$ by 1-inch negative from which the image on the screen is projected are so finely divided that they accomplish a proper relation of picture elements to this number; in fact, they go considerably further than this requirement. It is clear, then, that stepping from commercial peephole television to full projected television reproduction requires only solution of the projection problem itself. The terminal apparatus and the channel requirements for projected television will have been developed with the accomplishment of really good peephole television.

Effect of Enlargement.

However, it must not be concluded that a $\frac{3}{4}$ by 1-inch image of perfect texture can be projected to

DETAIL REQUIREMENTS OF TELEVISION

full screen size merely because that is accomplished in motion-picture projection. Such a field of reproduction of perfect texture, viewed at a distance of 10 inches, consists of not less than 87,894 picture elements, according to the calculation made. The image can be readily enlarged by lenses or merely by increasing the area viewed as a picture element. This process will at once sacrifice clarity of detail which can, however, be compensated for by moving the observer further from the scene. If the field of reproduction is moved 6 feet from the eye, it can be increased to 7.2 by 5.4 inches without sacrifice of texture. Greater enlargement without further separation of the reproduction from the eye subtracts from the detail.

Apparently there is no substitute for picture elements. The eye acts upon the information imparted to it. A given density of picture elements per square inch can be viewed without a consciousness of texture at a certain distance, according to the accompanying curve. Television receivers can readily be rated according to the number of picture elements per square inch of reproduction. Their fidelity can then be rated according to the percentage of picture elements per square inch by which they deviate from the minimum dictated by the resolving power of the eye when viewed at the distance from the eye intended by the designer. For example, 100 per cent potential fidelity is attained when the total density of picture elements per square inch is the quality which just satisfies the resolving power of the eye.

How Closely Perfect Texture Must Be Approached.

Highly useful and entertaining television can be expected from a somewhat smaller percentage of this exacting optimum quantity, just as we enjoy radio receivers which reproduce only up to 4,000 or 5,000 cycles, while the average ear can respond to as high as 17,000 or 20,000 cycles. The eye is more exacting than the ear, however, because it does observe exceedingly fine detail when viewing objects at rest. When the subject is in rapid motion, however, the eye is decidedly less exacting. In every type of activity there are periods of rest and it is only during such periods that the eye demands full detail. In waiting for an automobile race to start, for example, the eye is instantly conscious of lack of accurate detail in the fixed background of the scene, a condition which might be simulated by wearing glasses which put the scene out of focus. But once the cars start whirring around the track, the eye is quite willing to tolerate very poor detail. Consequently we may expect satisfactory television involving subjects in rapid motion at far below 100 per cent fidelity. Indeed, it might be established that the detail requirements bear an inverse relation to the rapidity of the action in the scene.

Just what percentage of perfect fidelity will serve in practice is hard to estimate, because such elements as contrast, degree of illumination and surrounding illumination modify the requirements substantially. For home projection, moderate illumination of the room must be tolerated, and that condition requires brilliance in the illuminated reproduction. Existing systems rely largely upon the neon tube, the illumina-

DETAIL REQUIREMENTS OF TELEVISION

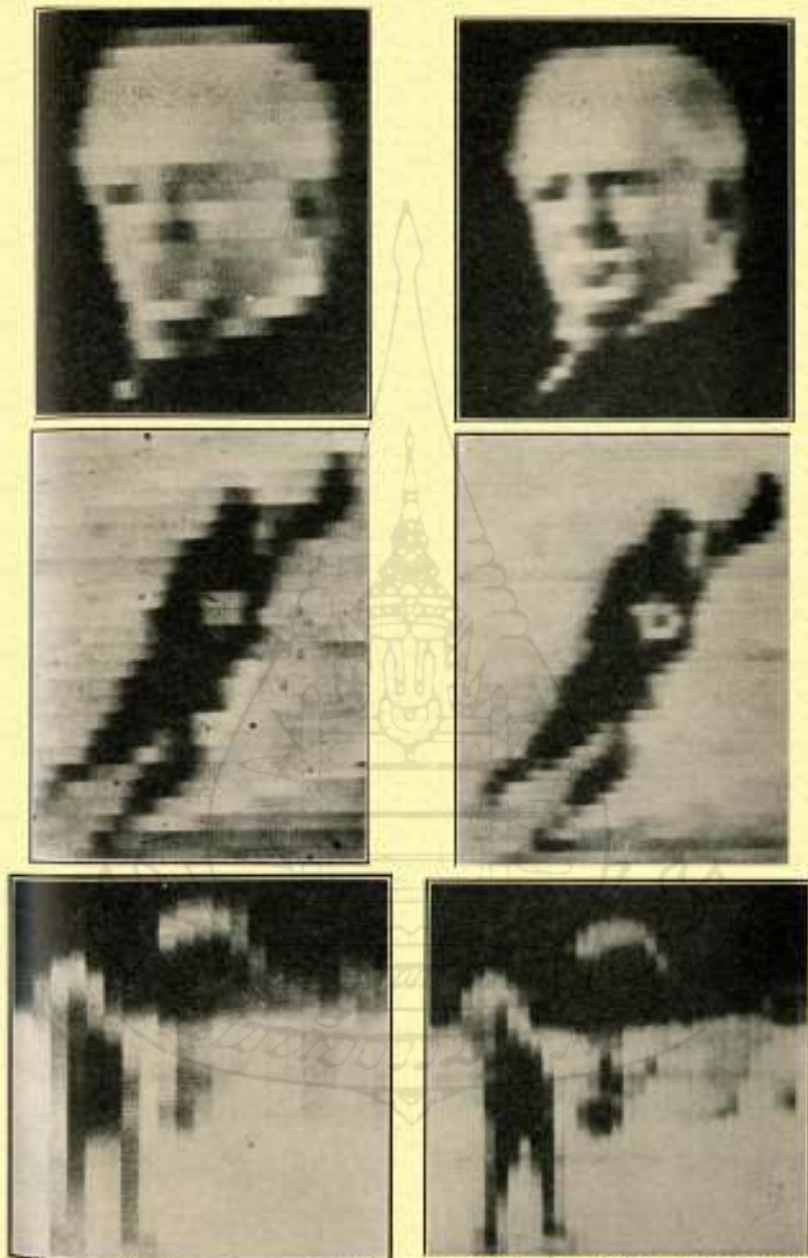

FIG. 66—The three pictures on the left are representative of the definition attainable if the picture signal is confined to a single broadcast channel; those at the right consist of 1,250 picture elements, which can be transmitted through 40,971, the equivalent of two broadcast channels. (Courtesy of Bell Telephone Laboratories.)

TELEVISION

tion of which is the product of the amplified signal. It would be desirable to develop economical light valves of a size suited to the home, as the source of illumination for screen projection. A motion-picture film acts as a valve intercepting and admitting an exceedingly powerful light source to a screen. Sufficient illumination is provided to produce from 3 to 22 foot-candles on the screen in commercial motion-picture theaters; the majority use 5 to 14 foot-candles. For 16-millimeter home projectors 1 to 15 foot-candles are used, with 7 to 8 foot-candles as a good average value. Persistence of vision varies according to the illumination and the weak light sources now used for television require a higher repetition rate to secure clear reproduction than would be necessary if the field of reproduction could be illuminated to higher intensity and deeper contrasts. Inasmuch as reduction of the repetition rate effects enormous channel economy for any given number of picture elements, the gain which would be accomplished by brighter illumination sources would be substantial.

Varying Repetition Rate Requirements.

Although we have determined the theoretical requirements of perfect television upon the basis of the resolving power of the eye, it appears that the practical requirements of picture-element density are modified by the nature of the subject matter. In viewing a reproduction of a panorama viewed from a plane in flight, the eye is extremely exacting in its demand for detail, searching down to the very limits of its resolving power. The action, under the cir-

DETAIL REQUIREMENTS OF TELEVISION

cumstances, is quite slow. We can, therefore, conceive of a low rate of repetitions as a means of compensating for the greater density in picture elements called for by such a scene. On the other hand, a slow rate of repetitions, such as 15 or 16 per second, would result in a blur in viewing an athletic event. We would hardly tolerate less than 20 repetitions for such rapid activity. And again, we would call for less detail while the activity is rapid. Thus these requirements are complementary and therefore tend to simplify the ultimate problem.

Because of these varying requirements imposed by the character of the subject matter, practical television may be somewhat more flexible in character than is now the practice. The control operator may have facilities for changing the repetition rate and the detail as required by the subject matter being televised, and the reproducer will have to respond automatically to these changes. Television programs will be monitored to suit them to the limitations of terminal equipment and channel, just as sound programs are today. Only until we have a communication system which has an ample margin of capacity, so that we can have both detail and speed without coming up against channel limits, will a fixed scanning speed and a fixed scanning density be anything other than a handicap to the development of the art. In this absence of flexibility, the television system will be limited to reproduction of scenes of a given character, either scenes of great detail and slow motion or those of little detail and rapid motion, depending upon the standards established. It is undesirable to consider standardization

TELEVISION

of repetition rate or elemental density until the future of the art is more clearly defined, except for the purpose of encouraging cooperative experiment.

Advantages Gained by Projection.

The curve of Fig. 67 brings out quite clearly the advantages of projected television over the more

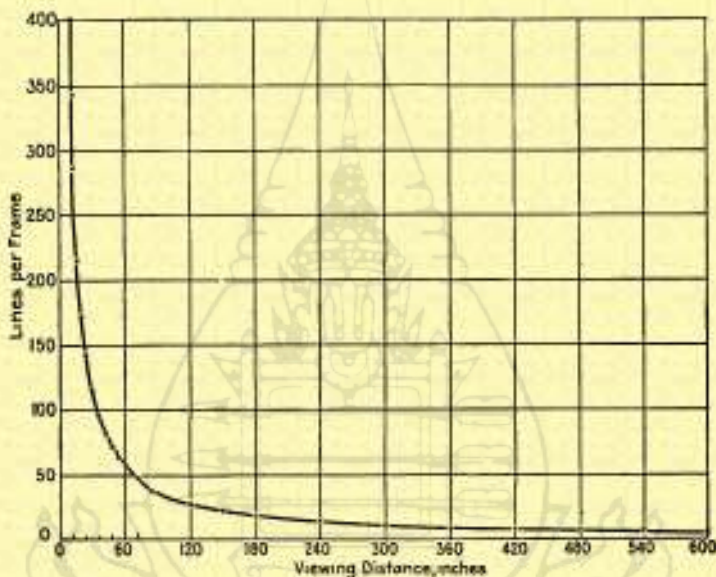

FIG. 67.—Lines per frame and viewing distance for perfect texture.

familiar peephole variety. As we approach the distance from the eye at which it perceives the greatest detail, the requirement in picture-element density rises substantially. At approximately 5 or 6 feet, the curve straightens out, bringing us to 60 lines per inch at 5 feet, or 3,600 picture elements per square inch of reproduction for absolutely perfect texture.

DETAIL REQUIREMENTS OF TELEVISION

FREQUENCY REQUIREMENTS FOR TELEVISION PICTURES OF VARIOUS DEGREES OF DETAIL

Lines	Picture elements per frame	Picture elements per second, repetitions			Maximum picture signal frequency, repetitions		
		16	18	20	16	18	20
24	576	9,216	10,368	11,520	4,608	5,184	5,760
48	2,304	36,864	41,472	46,080	18,432	20,736	23,040
72	5,184	82,944	93,312	103,680	41,472	46,656	51,840
100	10,000	160,000	180,000	200,000	80,000	90,000	100,000
200	40,000	640,000	720,000	800,000	320,000	360,000	400,000
500	250,000	4,000,000	4,500,000	5,000,000	2,000,000	2,250,000	2,500,000
1,000	1,000,000	16,000,000	18,000,000	20,000,000	8,000,000	9,000,000	10,000,000

TELEVISION

Inasmuch as various television systems have already been developed using 24-, 48- and 72-line scanning, it is of interest to establish the size of reproduction of perfect texture which can be attained, shown in the following table. The calculations have also been made for 100, 200, 500 and 1,000 lines. The communication channel requirements for transmitting television signals of these values at various repetition rates are also given.

LENGTH OF SIDE OF SQUARE REPRODUCTION OF PERFECT TEXTURE
Inches

Scanning lines	Viewing distance					
	10 in.	3 ft.	6 ft.	10 ft.	25 ft.	50 ft.
24	0.07	0.25	0.5	0.84	2.1	4.2
48	0.14	0.5	1.0	1.7	4.2	8.4
72	0.2	0.75	1.5	2.5	6.3	12.6
100	0.3	1.0	2.1	3.5	8.7	17.5
200	0.6	2.1	4.2	7.0	17.4	35.0
500	1.5	5.3	10.6	17.6	44.0	87.9
1,000	3.0	10.8	21.6	35.9	89.8	179.6

All of these calculations as to density requirements are based upon the assumption of perfect texture. The degree to which we may depart from perfect texture is dependent upon the information which is logically sought by the eye in observing the particular subject being offered. Obviously, we do not have to await the attainment of such exacting standards to render a useful service. The detail required in actual practice is debatable. In the early stages of commercial exploitation, considerable departure from theoretical perfection will be tolerated. As the novelty of

DETAIL REQUIREMENTS OF TELEVISION

television wears off, the public will demand improved quality, but whether the ultimate standard will be 10, 50 or 80 per cent of theoretical perfection will not be easily determined until somewhat better quality than is now attainable can be subjected to public criticism.

Estimating the Value of Existing Systems.

Assuming that we must rely upon a mere extension of present methods, we can analyze the present status of television quality. The simplest entertainment service which can be conceived is the televising of a single human face to accompany the broadcasting of an artist's voice. A clearly recognizable close-up of a face, but lacking somewhat in detail, it is true, is secured by 50-line television. Considerably better reproduction is obtained with 72 lines, the capacity of the system used in the Bell System two-way wire television demonstration.

However, the 72-line standard still leaves much to be desired, because no fine lines of the features and no expressive shadows are portrayed. The teeth are a single band of white, with no shadows to demark them. The reproduction is certainly markedly improved by scanning this kind of subject with 100 lines. The 72-line system requires 40,000-cycle capacity circuits, attainable over only very short hauls of wire lines. Increasing the requirements to 100 lines doubles the width of the channel necessary. A 72-line reproduction, however, is of a standard that constitutes a good visual supplement to a telephone conversation but, as the basis for an entertainment service, even a 100-line reproduction is not likely to be of permanent entertainment value. I doubt that

TELEVISION

the reproduction of such a picture signal, enabling the broadcast listener to see a close-up of the speaker or artist, would justify the cost of the reproducing installation necessary and the assignment of the frequency facilities essential to its distribution.

The requirements of an entertainment service are considerably higher than those of a mere communication service. Communication, whether of speech or vision, of a standard so low that some fatigue to the

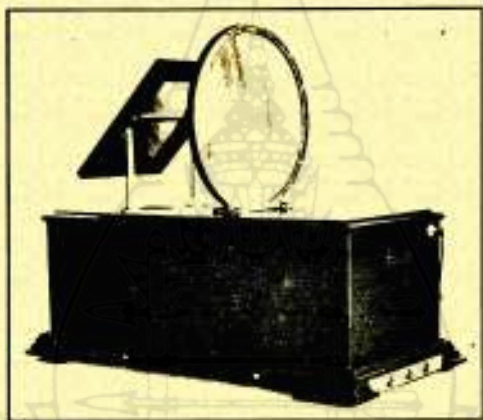

FIG. 68.—An early Jenkins television reproducer or televisor, with magnifying lens.

eye or ear is involved in utilizing it, is, nevertheless, useful and serviceable. Ordinary telephone circuits transmit an audio signal confined to a band between 250 and 3,500 cycles, but to hold the interest of a broadcast listener for sound-entertainment purposes requires faithful transmission and reproduction throughout a minimum band from 100 to 4,000 cycles and good response from 50 to 5,000 cycles. Television for communication and television for

DETAIL REQUIREMENTS OF TELEVISION

entertainment are, in a similar way, of two quite different standards. The entertainment value of a 72-line service limited to profile, three-quarter and full-face views of individuals will rapidly pass, in the hands of the average person, through the stages of an



FIG. 69.—A photograph of a 48-line television reproduction made at the General Electric Laboratories.

intriguing novelty, an occasional entertainment and an utter bore.

Minimum Requirements of an Entertainment Service.

Two full-length figures in action have much greater possibilities as entertainment subjects than a single close-up. They can gesture, struggle, box and fence. Simple dramatic situations are readily portrayed

TELEVISION

by a system of that capacity. Both by costume and activity, they can indicate different pursuits and situations. This is a minimum standard for a pioneer commercial television service offering program variety and real entertainment value.

In order to view two figures in action, the field of view must be fairly extensive. The actors must be given some space in which to move and there must be some, if limited, space for background. Perhaps a stage 8 to 10 feet square may be adequate for a starting point. The height of the space embraced by the scanning apparatus should be not less than 8 feet and preferably 10. In such a stage, simple dramatic situations of considerable variety and scope could be successfully staged. Viewed as a plane, this requires the scanning of a field of view approximately 100 square feet in area. For convenience in calculation, we will base the figures on an area of 100 by 100 inches in size, or a total of 10,000 square inches.

This rather extensive field can be scanned to various degrees of detail. Suppose, for example, we set as a minimum requirement that the individual fingers of the hand of each of the actors may be seen, not an unreasonable requirement considering the accomplishments of the motion picture. The scanning apparatus, under the conditions, must respond to light changes each tenth of an inch, requiring a system of 1,000 lines, clearly beyond the capacity of any television system so far conceived. A glance at the table of frequency requirements shows that our present methods of television demand, to transmit a picture signal of that density, too extensive communication facilities to make a system of that

DETAIL REQUIREMENTS OF TELEVISION

capacity a reasonable expectancy, so long as we are limited to those methods.

With 5 lines to the inch, there will still be considerable detail in the scene. The pupil of the eye will be darker than the rest of the eyeball; the buttons on the coat will show; a smile or a frown will be clearly portrayed. But 500 lines at 16 repetitions requires a 2,000,000-cycle channel, and we are not yet justified in hoping for such liberal communication facilities for television. If we scan the scene to but 200 lines, any element smaller than $\frac{1}{2}$ inch is blended as a single impression; the buttons of the coat merge with the rest of the coat; the eyes blur into mere dark shadows; the figures approach the character of silhouettes. But 200 lines will still be capable of portraying considerable detail if the subjects move closer to the scanning apparatus, thereby restricting the field of view, when facial expression and detail are of interest. Rapid action in the entire scene of 10,000 square inches will be not only discernible but entertaining. Experience has shown, however, that too much close-up is tiring to the observer. At least during the novelty stages, 200-line television will nevertheless be adequate to enjoy extensive public interest. Television of this quality and detail is within range of the experimental channels assigned to the purpose. The actual accomplishment of 200-line television requires the solution of many difficult problems and it will herald a period of further development leading to the establishment of standards worthy of permanent public support.

CHAPTER XIII

PROGRAM POSSIBILITIES OF TELEVISION

The program possibilities of television, at first sight, appear to be limited only by the breadth of human imagination. In the field of news and sports broadcasts, any event sufficient to arouse general public interest is a subject for a television broadcast; wherever the news photographer rushes with his camera is a logical place for the television pick-up; indeed, wherever people congregate to satisfy their curiosity, the radio eye has its place. In the field of entertainment, the motion picture, the drama, the musical comedy and in every form of spectacle, there is a logical foundation for a television program. In politics and education, the inanimate loudspeaker will be given new life and new means of holding audiences, with the aid of information portrayed to the eye. Radio humor has hitherto lacked the visual element; that is now to be supplied by television. The range of educational subjects effectively presented through broadcasting will be enormously extended when the lecturer can supplement his discourse with illustrations, drawings and charts through a television reproducer.

Television Programs Must Regard Technical Limitations.

It is manifestly impossible to discuss a subject of such broad range in a single chapter or a single volume;

PROGRAM POSSIBILITIES OF TELEVISION

indeed a man would be of barren imagination if he could not, in a few hours, evolve a thousand suggestions for television programs. The question to be considered here is merely a very limited phase of this exceedingly broad subject: the program possibilities of television in the light of the limitations imposed by existing methods of television.

During the early stages of television-program presentations, limitations inherent in the performance of television systems will preclude certain types of programs, and impose restrictions on the form in which others may be presented. Natural progress in the science will eventually free the art of television presentation of these barriers, one by one, and will leave unrestricted opportunity to creative talent. But until that freedom from technical limitation is established, the success of the television-program director will be measured by his ability to appreciate and understand the limitations circumventing him, and by his ingenuity in sidestepping these technical barriers.

Since the progress of the art depends upon public support, the more clearly the limitations are understood, the more can be made of the existing opportunities for effective presentation. Only by utilizing to the fullest what facilities we have available during the early stages of the art can rapid progress be made in building up audiences, thereby financing the essential improvements which must continually manifest themselves to merit continued public support. Therefore, although we may look forward to a progressive emancipation of creative talent in television-program evolution through technical progress, we must be

TELEVISION

prepared, from the first inception of television service to develop program interest.

Evolution of Television-program Direction.

The first television features have been evolved by the engineers who developed the apparatus used, as a part of the work of demonstrating the capabilities of their respective devices. So long as the objective is merely the demonstration of technical possibilities, showmanship is a secondary consideration. The next phase of program development is television as an experimental adjunct to the broadcasting station, and in this capacity it serves principally as an embellishment of the sound-broadcasting program. Until the technical quality of the reproduction is greatly improved, the television program will remain largely in the hands of the broadcast-station-program manager. This will be, or is, a critical period in television-program development, because the danger is ever present that television will be regarded only as a means of eavesdropping on the radio-broadcasting studio. Such a limited conception cannot long hold an audience, although it is sufficient to arouse initial interest. The absence of the visual element in sound broadcasting is realized by every program director and the facility of television will offer him a welcome opportunity to strengthen the attractiveness of his program efforts.

Vision, the Missing Element of Broadcasting.

The ability to describe the visual elements of a broadcast event in vivid detail is considered a primary qualification of a good news and sports announcer.

PROGRAM POSSIBILITIES OF TELEVISION



FIG. 70.—The first television drama, produced by WGY, September 11, 1928, was highly successful from the transmission and publicity standpoints, but satisfactory reproduction was not possible with equipment then available.

TELEVISION

His success depends largely on his ability to build a realistic image of the scene in the listener's imagination. To test this capacity of candidates for announcing positions, the program director of a leading station in New York requires them to stand at the window of his office and give a running description of what they see taking place on busy Broadway below. Television's ability to present the visual aspects of an event directly to the eye represents a tremendous enrichment of home entertainment by radio. The public clamors for the availability of what it imagines practical television to be.

Anyone familiar with the performance of available home-reproducing equipment, however, realizes that there is a considerable disparity between the attained reproduction and that which the public has been led to expect through the rosy publicity accorded to television. It would be much more conducive to public confidence if television news tended to have a closer relation to the facts, so that the curiosity it arouses would not be invariably dispelled by a disappointing reality.

Forty-eight-line Television as an Adjunct to Sound Broadcasting.

Even 48-line television, the pioneer service standard, has considerable program possibilities. But they can be realized only through intelligent showmanship and careful guidance of program policies within the existing limitations imposed by the pick-up and reproducing apparatus.

Because of lack of detail, 48- and 60-line television is necessarily only a supplement to a sound

PROGRAM POSSIBILITIES OF TELEVISION

program. When the mind is supplied with a wealth of detail regarding a scene through the ear, the eye needs little more than a suggestion to produce a vivid visual impression. Up to this time, however, most television programs of this order of quality have been presented without sound accompaniment, leaving the imperfect image produced at the mercy of concentrated attention. In those few instances where sound has accompanied such meager television, it has vastly improved the entertainment produced. We shall always remember Merle Trainer's pleasant humor before the pick-up during the first public demonstration of projected television at Schenectady. Had he performed in ghostly silence, the newspaper reports of that historic demonstration would have been concerned with a critical examination of the quality of reproduction rather than reflecting (as they did) the genuine pleasure experienced by the liberal representation of news and technical writers present. To be successful from the program standpoint, 48-line television features must be closely coordinated with sound and strong reliance placed on the entertainment value contributed by the sound element.

Humor Aided by Crude Television.

Humorous dialogue acts will receive a new lease of life with the aid of 48- or 60-line television as a supplement to sound broadcasting. Successful television comedians will learn the tricks of the television close-up and the highly contrasting make-up necessary to produce a visual effect. They will move up close to the scanning disc for a grin or a wink, so the maximum of detail will be concentrated in its reproduction.

TELEVISION

Since some of the most popular broadcasting features of the day lend themselves to such television portrayal, a wealth of program material is at once available to the broadcasting station with a television transmitter.

Broadcasting Studio Scenes as Television Material.

The natural tendency of program directors of television broadcasters will be to extend their pick-ups to broadcasting studios. Indeed, without portable scanning systems, television programs will be strictly limited to such scenes. Bands and orchestras do not lend themselves to satisfactory reproduction with only 48-line definition. Consequently, close-ups of solo artists are likely to predominate in early programs. So logical is this concentration of the television pick-up on the faces of baritones in pain and sopranos stretching toward the top notes, that it constitutes something of a danger to the commercial success of television. A face presented for television transmission must possess qualities which render it worthy of that distinction, or else television reception will be quickly branded as monotonous entertainment. Since this crude standard of television does not admit of fine graduations of detail, the grotesque features of a clown will be more impressive than the features of an outstanding beauty.

Television as an Aid to the Lecturer.

The successful lecturer and distinguished speaker, expounding before the television pick-up, will realize that he must hold the attention of the eye as well as of the ear. He will, therefore, learn to take the fullest advantage of the limited area of pick-up available to him. He will realize that he cannot hold his audience

PROGRAM POSSIBILITIES OF TELEVISION

by a mere exercise of his jaws. Therefore, he will turn his head from side to side slowly, presenting his face from every angle, wherever the context of his address makes that gesture natural. He will avoid quick motion as carefully as he avoids rigidity. He will appreciate the fact that the major motions, such as turning the head from side to side and tilting the chin upward, will make far more impression on those watching him than the modes of expression he has learned to use before audiences in the lecture hall. He will find that concentration of expression by closely focusing the eyes and hardening the lines of the face, which he has learned to assume when driving home a major point, will be totally lost on his television audience, equipped only with 48-line reproducers. Special lighting equipment to accentuate contrast in the face will be utilized to make the television reproduction more expressive.

Lecturers and speakers will take advantage of every possible opportunity to present charts and models of a character which are suited to television reproduction to relieve the observer of the monotony of watching the mechanics of a mouth in motion, a sight perhaps all too familiar in the average home to require the introduction of complex radio devices. Whatever is used as subject matter along these lines will be carefully tested before the television pick-up to assure that it is held in the best possible position to secure the greatest detail in reproduction and that every element to which the speaker refers in his talk is actually reproduced. This is a most important point, likely to be overlooked frequently by lax program directors. For instance, if the speaker, in describing the route of a trip, holds up

before the television pick-up a map of such detail that it is a meaningless blank in the reproducer, the audience will be annoyed by the lack of consideration so evidenced. If, instead, a crude crayon map, preferably drawn before the television pick-up, is offered, the action of drawing will hold the eye and the simplicity of the map will not exceed the definitive capacity of the 48-line reproduction. Likewise a conventional graph with a line too fine for the television pick-up to discriminate is an imposition on the audience, but the same curve reproduced in solid black from the base of the graph against a white background will show up clearly. Every attempt to show the television observer detail beyond the capacity of the television pick-up and reproducing system will be an annoyance which will merely emphasize the shortcomings, while careful observance of the limitations will make possible informative and appreciated features.

Subjects beyond the Scope of 48-line Television.

For the present at least, 48-line television is inadequate to handle extensive outdoor scenes, to pick up programs from the stage of the conventional theater or to reproduce athletic events. All of these possibilities have been promised by ambitious television publicists and the failure to perform has accounted for the lethargy of experimenters in supporting the industry. Statements have been made to the press that there are 15,000 to 20,000 television reproducers in the metropolitan area of New York City at this writing, but actually, there are not 1,000 in maintained operation. The number can be readily increased to

PROGRAM POSSIBILITIES OF TELEVISION

50,000 or 100,000, even with the crude 60-line reproduction now available, by merely utilizing intelligent program direction and avoiding promises which amount to misrepresentations.

Possibilities of 100-line Television.

Assuming that we are confined to present methods and principles, the availability of 100-line television represents the beginnings of general service to the public. This standard offers genuine entertainment and educational value without relying entirely on the experimental or pioneer appeal, or leaning too heavily on sound. The area which can be comprehended simultaneously is still limited, if reasonable detail is to be provided, but the area limitation is no longer of a magnitude to test the ingenuity of a good stage director. For the broadcasting of prize fights, the observer of 100-line reproduction has the equivalent of a seventy-fifth row seat, but coupled with vivid and accurate announcing, that is far from a minor service. One-hundred-line television can stand on its own feet and its inauguration on a practical basis will be a substantial bid for public favor.

The capacity of 100-line television system permits reproduction of full-length figures in considerable detail appearing on a stage of sufficient capacity to portray any type of room setting. Furniture, windows and doors are clearly distinguishable and can serve significant parts in the dramatic portrayal. There is ample room for two or three actors in major parts, and their gestures and motions are easily discernible, although, of course, close-up views of each actor individually must be relied on for details

of facial expression. Nevertheless, any simple dramatic presentation, involving a limited number of characters, can be run off smoothly without undue emphasis on the shortcomings of television by clever use of close-up and action.

Athletic events which do not require an extensive area, such as boxing and wrestling, are not beyond the capacity of television of 100-line quality. But outdoor scenes must be more carefully chosen, lest the field comprehended be too extensive to be portrayed in detail. By skillful restriction to essential close-ups, however, almost any event can be made interesting to the television audience, particularly when supported by capable announcing. Indeed, the advent of 100-line television introduces such a wide latitude to the scope of the television program director, that it is needless to consider more than certain possible developments which may increase the number of types of program which may be successfully presented.

Variable Repetition Rate and Detail.

The transmission of 100 lines at 20 repetitions requires the transmission of 200,000 picture elements each second. The possibility of lower repetition rates for the presentation of even more comprehensive scenes suggests itself forcibly. If we had some form of projector which maintained its illumination for a second after the originating light impulse was removed, scenes of fine texture and detail having 200,000 picture elements per frame could be unfolded before the observer's eye. A view from a plane in flight, for example, requires detail or wealth of picture elements, rather than a high repetition rate. If slow unfolding

PROGRAM POSSIBILITIES OF TELEVISION

of a scene over a period longer than is accommodated by persistence of vision is relied upon, the scanning progression must be carried out so that the scene appears logically before the eye either beginning at the center of the field of reproduction and expanding outward in an ever increasing circle, or building up from the bottom, simulating the rising of a curtain.

If the operator at the transmitting point could have complete control over the speed of operation of the receiving system over a wide range, great program possibilities would be unfolded which could not be handled by a single-speed system. In view of the possibility of television systems of variable repetition rate and picture-element density per repetition, the premature establishment of a fixed standard for the television repetition rate and scanning texture appears undesirable. The number of picture elements per repetition and the repetition rate may be altered by a skilled operator at will according to the requirements of the scene. He may use high-speed television for portraying rapid motion in a limited field of view and slow-speed television, equivalent to a rapid succession of still pictures, for detail, realism and comprehensiveness.

Program Possibilities of Flexible Detail and Speed Systems.

As an example of how a specific event might be handled with such facilities, consider the start of the first transatlantic dirigible as viewed through a system which can be arbitrarily altered through a range from a 100-line, 20-repetition rate to a 450-line image at the rate of 1 repetition per second. Such transmissions

TELEVISION

can all be conducted through communication channels capable of handling a 100,000-cycle band. At this outstanding news event, the television audience is first shown a close-up view of an express elevator in the lobby of New York's tallest skyscraper, where, a quarter of a mile above is moored the new transatlantic air liner. The announcer describes the busy scene and retails gossip about the notables who are making this the point of embarkation for the aerial transatlantic voyage. The field of view here can be restricted to a small area so that high-speed television is used to advantage. The audience is then given a view up the elevator shaft as the elevator travels its way skyward. This scene would, of course, also be transmitted as high-speed television. Any distortion which might be introduced by the rapid motion of the elevator would only increase the illusion of speed.

The next view might be of the dirigible itself as seen from the mooring mast with the city below as a background. The television pick-up would be carefully placed with no rapidly moving objects near it, so that the maximum detail could be scanned, producing an image of 200,000 picture elements renewed once each second and maintained by means of a fluorescent screen. The reproduction is sufficiently good to enable the announcer to describe the craft of the air in considerable detail to his listening and observing audience.

The next point of pick-up might be a close-up view showing the crew loading mail and baggage with feverish activity, which, very probably, continues at an accelerated pace only as long as it is under scrutiny of the television pick-up. The next view may again be a

still picture taken from the dirigible and looking directly downward at the city below, making the 1,200-foot skyscraper look as if it were 20 miles high. The next scene is again high-speed reproduction, this time of the officers of the dirigible saying farewell to terra firma, followed by a view of the dirigible casting off. At first high-speed television will be necessary, but as the ship moves further away, the repetition rate is progressively reduced, the detail correspondingly increased, until the ship finally stands out as a speck in the sky, with the panorama of the cheering city waving farewell.

The point I am attempting to bring out by this example is the fact that so long as communication channels remain a primary limit, the use of widely ranging repetition rates makes possible a great improvement in the program values of television broadcasting.

Television of Motion-picture Quality.

To assure to the television impresario as complete freedom of technical limitations as that enjoyed by the motion-picture director requires a considerably greater number of picture elements per frame than is offered by 100-line television. Remarkable as 100-line quality would appear in comparison with existing systems, it is, after all, only the definition embodied in a single square inch of magazine half-tone. Because television systems shade the entire field of reproduction while half-tones have only half their areas shaded according to the subject, a direct comparison between television picture elements and half-tone screen is

TELEVISION

invalid. A careful series of tests¹ made by Julius Weinberger at the time that he was in charge of the Research Laboratories of the Radio Corporation of America, established a number of values for half-tones which portray about the same information to the eye as television of various standards.

The equivalent of motion-picture clarity in television appears to require 1,000,000 or 2,000,000 picture elements per frame, a number which involves excessively heavy communication burdens, regardless of the channels used for the purpose. The probabilities are that before such standards are attained or even approached, television will have been attacked from new angles, such that the required number of picture elements can be transmitted without the necessity for 15 to 20 communication impulses for each picture element each second. The progressive scanning method is not the only one conceivable, although it has been adhered to so religiously by all the workers in the field that we are inclined to accept it as the only possible avenue of development. Just to indicate one alternative, a combination of still-picture-reproduction methods and television would permit the portrayal of subjects in motion without such an extensive quota of channel facilities. The transmission of a frame of motion picture as a facsimile or phototelegraph might be conducted at the comparatively slow rate of one frame each 2 seconds. When a suitable amount of film has been made in this way to complete a subject, it can then be exposed through a motion-picture

¹ WEINBERGER, JULIUS, T. A. SMITH and G. RODWIN, Standards for Commercial Television, *Proc. Institute of Radio Engineers*, Vol. XVII, No. 9, September, 1929.

PROGRAM POSSIBILITIES OF TELEVISION

projector. It would take 30 times as long to make the film as to expose it, but since the transmission of each frame is extended over 2 seconds, only one-thirtieth the channel facilities necessary to deliver the same quality by the conventional methods would be used.



CHAPTER XIV
COMMERCIAL POSSIBILITIES OF
TELEVISION

The advertiser and the user of radio broadcasting as a goodwill advertising medium have eagerly watched the development of television, impatiently awaiting the day when it will give them their opportunity to exhibit their trade-marks and products in the homes of a vast army of potential buyers. The inauguration of television as a practical service will win widespread attention through the aid of the newspaper and the broadcast station. The first satisfactory programs will command a position in the limelight, of immense advertising value. We may expect then that the first evidence of public enthusiasm will witness a feverish rush on the part of advertising organizations to utilize the new facilities, differing only in its greater magnitude from that which accompanied the discovery that the public would listen to radio telephone broadcasting in 1922 and 1923.

But only in this single respect is the real start of television likely to resemble the inception of broadcasting service. Sound broadcasting started without a plan for its economic support. The biggest question in the minds of station operators was how long the radio fad would survive. At first each advertiser erected his own station until overcrowding of channels

became a serious problem. The American Telephone and Telegraph Company, with station WEAf, began a large scale experiment in selling time, which eventually resulted in the development of sponsored programs and chain distribution. Several years of intensive selling effort were required to establish broadcasting as a legitimate medium for advertising and several more years before agencies generally were equipped with personnel suited to handling radio-broadcasting problems for clients. All of this evolution took considerable time, with the result that radio advertising progressively and gradually reached the status of today.

The Beginnings of Commercial Television.

Television will find a complete structure ready to commercialize it. Broadcasting stations have organized personnel and established contacts in the advertising field, the advertising agencies have specialists in handling radio problems for their clients, and the advertiser is already accustomed to radio as a medium of approach to the public. Consequently there will be no long period of adjustment and development. Advertising will be ready for the visual medium long before the medium is ready for advertising. While television reproducers in the home are still one of the seven wonders of the world, the first television advertiser will intrude his billboard in the home. The embryo days of radio broadcasting suffered no such handicap; direct advertising, as it is practiced today by all stations, did not begin until news of the studios had long been relegated to the inside pages of the newspapers, and the number of columns devoted to it

TELEVISION

carefully regulated by the amount of paid advertising from radio manufacturers.

Economic Structure for Support of Television Broadcasting Established.

Television must go forward suspected if not conspicuously branded as an advertising medium. That assures it only perfunctory publicity support in the press, because the newspapers are no more interested in assisting competition than any other kind of business enterprise. On the other hand, while broadcasting had to rely on the press to become known, television can go forward no matter how successfully the newspapers may contrive to shun it. Television is associated with radio broadcasting and it therefore is quite independent of the press so far as publicity is concerned. Its association with the broadcasting medium is so close that television advertising technique will be largely imitative of the broadcast advertising technique as to method and standard.

The prospect that television will be supported by means other than advertising programs appears exceedingly remote. The precedents established by sound broadcasting apply so logically to television that it will be next to impossible to establish the newer field on a different basis. The public prefers to pay for broadcasting indirectly, either by purchasing products advertised by radio in larger quantities so that production costs are reduced, or, if that is impossible, paying more for the goods themselves. It cannot be expected to reverse itself with television and pay for the service rendered directly through taxation or subscription, although it would, in that way, be

COMMERCIAL POSSIBILITIES OF TELEVISION

Charles "Slim" Timblin Riotously Funny at RKO-Proctor's

What's News Is Another Headliner

SEE THE AMERICAN THEATER
"THE BOSS"
"THE BOSS"
"THE BOSS"

See It & Get
D-D-RIVE-IT
FIRST NIGHT

**A Supreme Event
Of This Century**
Will Take Place
**In Schenectady
Today**
When, at 8:30 P.M.
and 10:30 P.M.
and 10:30 P.M.

**RKO Proctor's
Theater**
In Grand Attendance With
The Finest Feature Company Will Present the
**First Showing
In the World**
Of the New Electrical Science

TELEVISION
A Science That Transmits Pictures
A Science That Shows the Real World
A Science That Shows the Real World
A Science That Shows the Real World

Specialty for the Entertainment of Tomorrow
Will Not Happen, Be Recorded by
**The People of
Schenectady**
When, at 8:30 P.M. and 10:30 P.M.
and 10:30 P.M.

TELEVISION
GARY COOPER
7 DAYS
LEAVE

STRANG
YELMA BANKY
A Lady to Love

STATE
The golden calf

"OLD EVERTING"

**BE AMONG THE FIRST TO SEE
TELEVISION—TODAY
AT RKO PROCTOR'S THEATER**
In Schenectady, N.Y.

FIG. 71.—The first advertisement of a television performance on the stage of a theater appeared in the Schenectady Union-Star, May 22, 1930. (Courtesy of General Electric Co.)

TELEVISION

relieved of the necessity of submitting to visual advertising.

Association of Television with Broadcasting.

The same corporate structures which dominate the radio and broadcasting industries are carrying out the major researches in television. Consequently, television is inevitably associated through every element of its fabric—research, manufacture, communication facilities and advertising—with the existing sound-broadcasting structure.

Television is a welcome addition to sound broadcasting, the program development of which has slowed up decidedly in the last few years from the standpoint of news and novelty values; television promises a revival of public interest in every element of the radio field. The manufacturers of radio receivers suffer from vastly excess production facilities and hopefully await the stimulation of television. The broadcast advertiser appears to have come to the end of his ingenuity in devising features which captivate the listener. All the frantic efforts of broadcasting organizations to arouse the listener from the attitude of complaisant acceptance, such as international rebroadcasting and special pick-ups of news events from airplanes and destroyers, have produced hardly more than a ripple of response. The public simply accepts broadcasting as a service which is acceptable if well performed. The blatant direct advertising is accepted as a necessary and unimportant evil, no more troublesome or conspicuous and no less effective than billboards on the highways, car cards on trolleys and

buses, and advertising columns and pages in newspapers and magazines.

From every standpoint, therefore, we may expect that television, once it takes hold with the public, will be intensively exploited under the direction of the personnel or organizations experienced with sound broadcasting. So logical is this conclusion that we may predict that the same program and advertising standards will apply to the mediums which have been evolved for sound broadcasting. Probably only slight changes will be made to adapt programs to television opportunities, because long training in the field inevitably molds the imagination to established formulas. The television pick-up will simply take its place at the side of the microphone, and television will be little more than an extension of sound broadcasting. When the quartet sings, you will be able to see it as well as hear it; when the announcer talks about throat irritation, he will point significantly to his Adam's apple; and when he describes the spotless factory, that intensely interesting sample of standardized architecture will appear in the television reproducer.

Influence of Television on Program Types.

As the standards of visual portrayal improve, television will tend to influence the character of programs which predominate in the schedules. The script program, which rose in a relatively short time from insignificance to a predominant position, will be greatly strengthened by good television portrayal. In fact, its possibilities will be so enhanced that the script is likely to be overdone. The average listener cannot devote much more than half an hour or an hour

an evening to the concentrated attention required by a script feature and, therefore, too many script programs will gradually tend to reduce audiences, despite their prospective effectiveness. But any such influence will be counterbalanced by the added attention given to the feature by its following as a result of the tremendously increased vividness and entertainment value contributed by effective visual presentation of the dramatic performance.

The musical-comedy type program will encounter some difficulties because of the limitations of television reproduction. Large choral and orchestral groups for adequate portrayal require a television system of considerable capacity, and it is likely, during the initial stages at least, that our view of such features will be limited to a few solo and specialty artists. Dancing, the stand-by of the musical comedy, requires an extensive field of reproduction for effective presentation, but the skillful director will devise specialties which can be successfully reproduced in close-up range.

Advertising by Television.

The broadcast advertiser relies on opening and closing announcements for the capitalization of his goodwill program. The mere extension of television to such announcements can materially add to their influence. The trade-marked package can be shown to the audience instead of being merely described, and the cigar advertiser who appeals to the young man can actually demonstrate that cigar smoking will make any man look like a major executive. In fact, since television reproduction of tobacco smoke is undeniably

realistic even with the crudest system, television can count on liberal support from the tobacco companies. The food advertiser, too, will find television a powerful adjunct to his broadcast advertising. A reproduction of a luscious strawberry shortcake is much more effective in creating an appetite than any word of mouth description. The real estate advertiser can show his model home, and the motor-car maker his latest body styles. In every field, the effectiveness of the radio medium will be enormously enhanced by television of a satisfactory quality.

We are promised, for the first time, a medium of dual appeal, both to the eye and to the ear, reaching directly into the home. If television progresses technically as rapidly as did sound broadcasting in ten years, a decade of general service will make it the greatest medium of expression for the advertiser. The printed page has held its own against sound broadcasting because of the superior information capacity of presentation to the eye. But radio communication of both sound and sight will eventually make that combination the most powerful medium for sales stimulation.

Adapting Television to Testimonial Advertising.

Testimonial advertising has been extensively utilized both on the printed page and through the radio medium. The routine technique for presenting testimonials may be followed when television supplements sound broadcasting. The announcer may read the prepared statement while the television system scans a photograph of the endorser. But bringing the endorser before the microphone and television pick-up

will so greatly increase the effectiveness of the testimonial presentation that it is likely to become the customary way of utilizing that advertising device. It involves a process somewhat more difficult and expensive than the established method. An agency copywriter prepares a written statement of endorsement designed to fit the product in hand and the scruples of the intended endorser. Then a high-powered salesman visits the executive or society leader whose signature is required and with the assistance of a check, the size of which varies according to the standing of the person involved, overcomes his natural reluctance to submitting to this undignified procedure. The whole thing is over in a minute, so far as the endorser is concerned.

To deliver the same testimonial by radio and television may require that the endorser be persuaded to visit the broadcasting studio in person. He must then read the prepared speech with more than a show of sincerity; his voice must carry conviction and his face must show no embarrassment. The use of radio in political campaigns has already shown how effectively the voice reveals the character and the conviction behind it. Perhaps television may eventually restrict the advertiser to *bona fide* testimonials.

On the other hand, an endorsement delivered sincerely by a qualified authority will undoubtedly prove tremendously effective. An eminent physician presenting a *bona fide* recommendation will win the respect he deserves. But the tittering society leader who does not know what she is talking about may no longer find the mere possession of a name an avenue to easy money. Television will confer a great boon to

advertising by tending to limit the testimonial to its proper sphere and increasing the effectiveness of the genuine endorsement.

New Types of Advertising Presentation.

Combined sound and visual radio presentation will offer opportunities to make direct advertising appeals without losing audience. Because we have the attention of the reader of the printed page for only a moment, the most effective appeals are generally superficial. The story must be comprehended at a glance and the copy must, therefore, be brief. Attempts to present technical points, on which the relative superiority of products really depends, have not been considered successful because they call for too much effort on the part of the reader.

With sound broadcasting alone, direct advertising is conspicuously blatant and annoying. But the high cost of sound broadcasting makes the direct advertisement unavoidable. The conception that the advertiser relies on capitalization of goodwill has been displaced, and the purpose of the program now is to win listeners so that they may have their receivers tuned to the station used when the advertising is broadcast. What is needed in broadcasting is a means of delivering the advertising message without the accompanying reaction. Television offers that opportunity. It permits the extension of human interest to the advertising announcement and the use of subject matter far beyond the scope of sound alone.

An interesting speaker, aided by models, photographs, diagrams and the product itself, can present even a technical story in two minutes which can be

TELEVISION

grasped by the average mind without conscious effort. He can get over more information in that time than could safely be embodied in ten advertising pages. A story which presents real information is vastly more interesting than the unmitigated bunk which constitutes the average radio advertisement of today. This superficial character of advertising substance is very largely due to inherent weaknesses of the medium used and rarely to any real lack of fundamental points which might be presented. So long as the listener's interest in a product is merely casual, the advertiser receives only a moment of attention requiring no conscious effort on the part of the prospect. Television with sound makes it possible to remain within these limitations and still to present a point of real substance and significance. The utilization of this opportunity is surrounded with difficulties, but skill in preparation of copy and exhibits and selection of a suitable voice and personality to present them will make possible the use of the radio medium for effective and interesting direct selling.

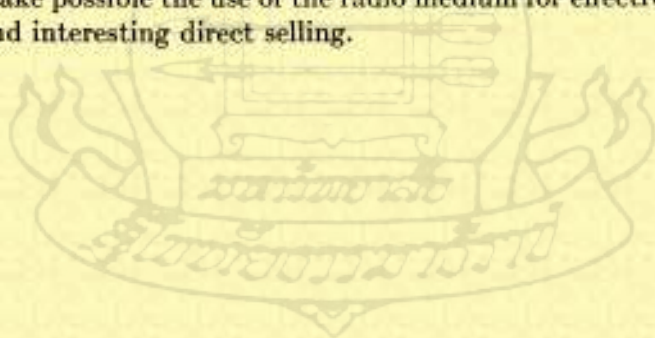

CHAPTER XV
ESTABLISHING A TELEVISION
ENTERTAINMENT SERVICE

The sweep of enthusiasm which accompanied the general recognition of the possibilities of radio broadcasting several years ago has naturally led to predictions of a similar wave of public interest upon the inauguration of television broadcasting services. Indeed, the program possibilities of television and the superior perception of the eye make logical the anticipation of an even more enthusiastic reception for practical television. It is no wonder, then, that a ready public and the radio industry have listened with eager ears to rumors of the availability of television. Indeed, television has been so long expected that we are inclined to complain of its slow progress.

However, broadcasting was many years in the making before its spectacular entry to commercial acceptance in 1922 and 1923. Many years before KDKA broadcast its first program, numerous experimenters broadcast entertainment programs by radio telephony on regular and frequent schedules for the benefit of experimentally inclined amateurs, serving audiences more numerous than the family of television experimenters of today. Thousands of people heard these broadcasts and marveled at the skill of the young wizards who assembled crude receivers capable

of intercepting them. A considerable number of companies, some of them the forerunners of the great radio manufacturing organizations of today, were engaged in making components for a brisk amateur trade. The general public did not anticipate a broadcast structure as it exists today because there was no example of a similar service, but it nevertheless marveled and waited. With the example of broadcasting before us, it has been easy to visualize the possibilities of television and this has stimulated expectancy all the more.

Essentials to Public Acceptance.

Broadcasting had to await the accomplishment of three requirements to win public acceptance: (1) reliable and satisfactory programs sufficient to justify sustained interest; (2) simple automatic home equipment requiring little or no special skill in operation; and (3) inexpensive receivers assuring an adequate return in entertainment value for the investment.

When KDKA began its service, receivers were far below present-day standards, but they possessed to a substantial degree the elements necessary to public acceptance. The first purchasers of radio receivers were so-called experimenters who desired to bask in the reflected glory of the wizards who had made radio possible. Their patronage made possible intensive commercial development which brought radio rapidly to the point of general acceptance on the basis of its service alone.

Television is in the status of radio-telephone broadcasting prior to the general availability of low-cost vacuum tubes. Experimenters with some technical

A TELEVISION ENTERTAINMENT SERVICE

skill and patience can, in various parts of the country, enjoy crude reproduction of visual broadcasts. But neither the character of the programs, nor the cost, performance and quality of reproduction attainable with such equipment as yet justifies general public support.

Requirements of the Experimenter Element.

Even for an appeal limited to the experimenter market, service requirements must be met. Although the pioneer television enthusiast will be no more exacting in his requirements for fidelity of reproduction than his predecessor in the early days of broadcasting, he will not support a budding television industry unless he is certain of a recognizable reproduction after only a moderate effort. His kit of television parts must be assembled in a few hours with only such simple tools as a screw driver, a pair of pliers and a soldering iron. Perhaps the general availability of reliable 60-line television service and kits which can be built up and made to operate in not more than 6 hours of home labor and at a cost not exceeding \$50 will bring the beginnings of a television industry. But even experimenter support cannot be long retained unless there is rapid improvement in the art, just as there was in broadcasting in its early days.

It may be held that the requirements set forth in respect to both reproducers and program services of a standard sufficient to interest the experimenter have already been met. Some 30 stations have been licensed for experimental television by the Federal Radio Commission, of which a small proportion are maintaining regular schedules, including one at Jersey

City, serving the New York metropolitan area, another at Washington, D. C., and a third at Chicago. One manufacturer is offering the public three types of television reproducing equipment for 60-line, 20-repetition service. The reproducer chassis includes a 760-cycle eddy-current motor to effect synchronizing from the initial impulse of each line, scanning disc, viewing lens and necessary mountings, and it sells for \$75 assembled. The same equipment mounted in a cabinet completely light shielded for efficient observation in daylight costs \$395. A special radio receiver, with power supply, covering from 100 to 150 meters and responding to from 15,000 to 30,000 cycles is offered for a list price of \$175. But it appears that the experimentally inclined buyer of radio equipment does not yet feel that the three requirements (1) entertaining programs, (2) foolproof and reliable equipment and (3) low-cost reproducers representing a fair return on the investment have yet been produced.

Television of 1930 Compared with Broadcasting of 1922.

Television, as it is today, is receiving far less support from the experimentally inclined than did broadcasting of 1922 and 1923. Yet, if the status of the two arts at these periods can be fairly compared, they will not be found to vary greatly in standard of program material offered or in fidelity of reproduction attained. The first sound broadcasts were practically all limited to presentation of individual artists. The pick-up of orchestras with the microphones then available was wholly inadequate and unsatisfactory. Reproduction, likewise, was so limited in range that it could not claim musical value. At the most, recognizability was the

A TELEVISION ENTERTAINMENT SERVICE

standard offered. The reproduction attained by a 1922 radio receiver through the loudspeakers then available, if compared with a modern receiver, would appeal to any listener as truly ludicrous. The first loudspeaker on the market was a small tin spiral affair, reminiscent of the old bulb-type automobile horn. We hardly appreciate how rapidly reproduction quality has advanced in ten years. From the standpoint both of range of pick-up and of fidelity of reproduction obtained, television of 1930 is very nearly on a parity with broadcasting of 1922.

More than half a million people built their own radio receivers during the first three seasons that this low standard of broadcasting was generally available. The public overlooked the shortcomings of radio reception and hailed it as a marvel and a mystery. The new industry rose rapidly to prosperity in a period of industrial depression. The rapid technical progress made in its halcyon days would have been impossible had it not been for the liberal public support which it enjoyed from the first.

But television, with probably as much to offer the experimenter in 1930 as broadcasting in 1922, and perhaps even more, has failed to attract a following in any way comparable to the enthusiastic group of experimenters from whom were recruited many of the leaders of the radio industry which they helped to create.

The failure to develop a large group of interested experimenters in the television field can be largely ascribed to loss of confidence occasioned by unwise publicity and to failure to take advantage of the program possibilities of 60-line television. Limited as these possibilities are, they offer as much opportunity

to make news and arouse human interest as was at the disposal of the pioneer broadcasters.

But performance must take the place of the kind of promises with which the television industry has fed a gullible and willing press. The continued appearance of such romantic stories as "television broadcasts from airplanes in flight," "presidential inaugural ceremonies" and "high-quality reproducers before Christmas," before the technical facilities to make them possible are developed, has caused the public to classify television publicity with that originating from makers of magnetic belts for curing rheumatism and snake oil for sharpening razors.

The tendency to unrestrained exaggeration in television springs from sources on both sides of the Atlantic. British newspapers publish excited stories about television feats in America, while American newspapers make themselves ludicrous by describing as remarkable such stunts as synchronization of speech with action accomplished in a British demonstration of television drama. If speech and vision picked up simultaneously by microphone and photocell and directly radiated could be transmitted *out of synchrony*, it would be news because that, at least, would involve an electrical delay system of widespread application in long-distance telephony and in overcoming distortion with synchronized broadcasting. Were the effort expended to secure publicity diverted to producing features within the capacity of the 60-line systems now operating, it would help materially to develop a following for television which the industry badly needs.

If the curtain rose suddenly on a perfected television service offering as regular program features all the

great outstanding news events, performances by stars of the stage and screen, major athletic events and occasional glimpses of remote parts of the world, the public would hasten to spend a billion dollars as fast as a busy television industry could deliver the apparatus.

The realization of these opportunities has spurred scientific research in the field and opened newspaper columns to television. It has encouraged the investment of capital and the initiation of manufacturing. But at the present writing television can hardly be styled a busy industry.

Reasons for Lack of Support to Television.

The lack of public support to the existing television services is in a large measure due, as has already been said, to premature promises and to failure to offer programs for the eye which could arouse the slightest public interest. The program possibilities of 60-line television are perhaps greater than the technicians in charge of producing them seem to realize. Furthermore, while recognizable images are easily obtained, we are far from the final refinement of 60-line reproducers. Although 60-line television is limited to a small field of view, it nevertheless provides ample entertainment for the experimentally inclined, whose interest lies principally in securing a recognizable reproduction and then improving its quality. It offers a practical opportunity to become acquainted with the fundamental design and service problems which are likely to exist, in less exaggerated form, it is true, when the art reaches a commercial standard. Those who have grappled with the difficulties as they

exist today will be fully equipped to progress with an industry destined to become one of major importance.

The real problem of the industry, then, at the present time, is the utilization of facilities that already are available. It must arrange for proper association of sound with visual programs, and the design of radio receivers which automatically reproduce both elements of entertainment. The sound and visual elements of the program must be profitably combined for radiation by the same carrier and filtered in the receiver to actuate sound and visual reproducing systems. Reproduction must be removed from the peephole category and developed to the point where even the simplest of home reproducers can entertain a family group simultaneously. Synchronization and framing must be taken out of the classification of a sporting proposition and made automatic and reliable. The program policies of television broadcasters must evolve rapidly beyond the present state in which the mere radiation of an image is all that is attempted. Programs must offer entertainment and educational material unavailable by other means and of a character making some discernible appeal to the intelligence. Finally safeguards must be set up against the extensive advertising uses of television so that it does not promptly create an unfavorable public reaction, just at the moment when audiences are beginning to be built up.

All of these measures do not call for any technical or policy developments which offer any very serious problems. They require only a deliberate cooperative effort of broadcaster, manufacturer and research

A TELEVISION ENTERTAINMENT SERVICE

engineer under competent and understanding executive guidance.

Taking Television Out of the Experimental Classification.

Having taken the steps necessary for a sound foundation for an appeal to the experimenter class, the immediate concern of a television industry is rapid and continued development in television transmission and reception. The brilliancy and contrast of the reproduction must be steadily improved to the point where no eye fatigue is entailed in observation over relatively long periods. The receiver must be automatic in its operation, and all manipulation concerned with synchronization and average shading values must be eliminated. If continued public support is to be maintained, the reproduction must rise quite rapidly from 60 to 100 lines, so that programs do not remain long restricted to crude reproduction of individual faces. But it is not necessary to jump from 60-line portrayal to a value sufficient to handle extensive outdoor sports events in a few months. So long as improvement is steadily maintained, the scope of the field of view within range progressively increased and fidelity of reproduction improved step by step, public interest will be sufficient to maintain a successful industry. Even if we should never arrive at the point where extensive fields of view, like that seen from an airplane in flight, or a comprehensive view of a football field in its entirety, will be within the capacity of television reproducers, the development of general service is by no means precluded. We may even be limited to a stage 20 feet wide for another half century,

but a limitation of that character would not prove a tremendous obstacle to the development of a substantial television industry.

Handling Sporting Events with Systems of Limited Field.

The public is particularly interested in the possibility of enjoying sporting events through television reproducers. The technical problems involved in picking up such an extensive scene as a football field in sufficient detail to observe the plays appear to be, with our present knowledge of the art, wellnigh insuperable. But even if we remain limited to a field of view 20 feet wide for a long time to come, it will be possible to give an entertaining representation of such an event. Portable scanning equipment in charge of skilled operators accompanied by competent announcers can maintain a continued series of close-up views portraying all the important high lights of the game. The observing audience will be in the position of a person watching the game at a considerable distance through a pair of binoculars. While they will not be able to view the entire field at any time, they will nevertheless enjoy a reproduction of that small portion of it where intensive action is taking place.

The development of sound broadcasting received its greatest impetus from major prize fights. The Dempsey-Carpentier fight from Boyle's Thirty Acres, broadcast with Major J. Andrew White at the microphone in 1923, made WJZ famous overnight. The Dempsey-Firpo fight, a few months later, proved such an exciting radio event that it added tens of thousands to the growing army of pioneer radio enthusiasts.

A TELEVISION ENTERTAINMENT SERVICE

Because prize fights take place in a field of view of limited scope, they offer television its greatest opportunity to spring to the forefront of public attention. It requires programs of this character, rather than programs taken from a silhouette film of a child bouncing a ball, to build up initial audiences. Limited as is the scope of 60-line television, the program value of the offerings so far presented has tended to depreciate to a minimum the service attainable with that quality of television.

Necessity for Close Association of Television Broadcasting with Reproducer Manufacture.

The problem of receiver design may tend to fall into hands somewhat disassociated from the interests having charge of the broadcasting of television programs and the design of pick-up apparatus for the purpose. With sound broadcasting the disassociation of the engineers in the two phases of the science, transmission and reproduction, did not lead to particularly harmful results because channel spacing, carrier frequencies used and audio-frequency ranges employed were naturally standardized by the allocations made to broadcasting stations. Each group could develop its equipment independently, without requiring radical changes in the course of the other. New microphones and studio amplifiers could be developed, new studio acoustics and pick-up systems devised, extensive wire lines and methods put into operation, without requiring corresponding alteration in receiver design.

In the television field, the two phases of development must be somewhat more closely coordinated. To secure the most effective results, progress in one

TELEVISION

field should be closely reflected by complementary changes in the other, and the inevitable compromise between the conflicting requirements of the two made in a manner which secures the best overall result. The specifications of radio receivers must reflect every improvement in television transmission, such as changes in scanning method, number of lines, contrast embodied in the picture signal, size of reproduction, scanning motor speed and, indeed, every detail which might be specified in a set of standards.

Premature Standardization Will Impede Progress.

We have had one attempt to fix standards for the television industry by a group of radio manufacturers. These standards specified the number of frames per second, direction of rotation of scanning disc, scanning-disc speed and several other details. The standards were adopted in order that there might be no unnecessary confusion and that all experimenters in the field might work along the same lines. But from the moment that these standards were adopted, there was opposition to them. Progress is certain to be impeded by any fixed standards, at least until we arrive at the point where the attained reproduction in home television is sufficiently good to justify public support purely on the ground of education and entertainment values.

An instance of the kind of thing which may upset any premature effort at standardization is the possible alteration of frequency assignments made to television by the Federal Radio Commission. Five channels, one of which is limited by preferential rights to foreign countries in this hemisphere, have been

devoted to experimental television services. These five channels have been squeezed out of a part of the radio spectrum which is intensively utilized for many different kinds of commercial services. The prospect of enlarging this band by extensions in its immediate vicinity is exceedingly remote. Congestion is, therefore, bound to set in as soon as a practical service is rendered which cannot as easily be disposed of by synchronization of carriers, the hope of solution for congestion in the broadcast band.

In broadcasting, it is a relatively simple matter, from the technical standpoint at least, to distribute programs and controlling frequencies over wire networks so that the same channel may be used simultaneously in different parts of the country. But wire networks have not yet been adopted to the distribution of such broad bands of signals as are required for high-quality television. Consequently, numerous independent transmitters are necessary to national coverage and a great number of transmitters cannot be accommodated on five channels. Either the signal band requirements of television of commercial quality must be reduced or else a new band of wavelengths for television purposes must be unearthed. In absence of a radical change in transmission methods, therefore, channels for numerous transmitters can be found only in the ultra-high frequencies not now utilized for other services. Any move in that direction would render obsolete receivers made with only the existing experimental channels in mind.

In view of these and many other considerations, it appears that any effort in the direction of standardization is premature, necessary as standardization is from

TELEVISION

the standpoint of commercial development. Even if we go too far in indicating common trends, we are likely to deflect the course of technical development of television along the lines which will restrict its progress. The technical future of television must be somewhat more clearly demarked before it is safe to attempt to crystallize such design details as number of scanning lines per frame and number of frames per second. Any standards so fixed accommodate the needs of appliances which are likely to be displaced by instrumentalities of greater flexibility and capacity.

Any attempt to predict the date of the emergence of television from the laboratory to general service must take into consideration not only the technical status of the science but the leadership developed by the industry. While the burden remaining on the shoulders of the laboratory technician are considerable, the greatest opportunities for service to the industry lie in its intelligent direction, to the end that the utmost use be made of the facilities which it already has available to it. The development of that executive talent has as much to do with determining the date when the television era will unfold as have the tasks remaining unfinished in the laboratory.

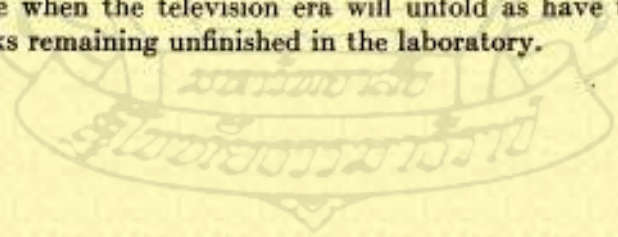

CHAPTER XVI
INDUSTRIAL AND COMMERCIAL
APPLICATIONS OF TELEVISION
APPLIANCES

Various types of apparatus, using elements developed for television transmission and reception, present opportunities for profitable research and manufacture to the forthcoming television industry. Considering the seasonal character of radio-receiver production, which depends upon similar buying impulses, television manufacture is quite certain to exhibit the same profit-absorbing seasonal characteristics. Large research and royalty costs are likely to be a heavy burden, at least during the earlier years of operations. The contribution of by-product fields to building up a stabilized industry is, therefore, a matter of the utmost practical importance to the manufacturer and engineer alike.

Relation of By-product Applications to the Television Industry.

In using the term by-product, I am assuming the existence of an established television industry with general public support. Prior to the attainment of such commercial status, these by-products are the established field and television is the experiment, just as ship-to-shore and transoceanic radio telegraphy was

once the commercial reliance of the radio interests while radio telephony was an experiment. Today the once all-important radio-telegraph business is considered so foreign to the main occupation of the radio interests that only a clause of the White Act prevents its sale to other communication interests. Eventually television manufacture will consider facsimile and industrial applications of devices used in television only as by-products, which were once useful in maintaining manufacturing schedules during seasons dull for television and in bearing a part of the research costs.

The television industry itself will at first be largely a by-product of the radio industry. The electrical elements of television reproducers are, from the production standpoint, similar to radio receivers, although electrically there is a vast difference between amplifiers for handling such comparatively narrow bands of signals as are involved in musical reproduction and the wide bands required for commercial quality television. Furthermore, television reproducers require association with radio receivers of special characteristics which, electrically, differ widely from broadcast receivers, but, mechanically and structurally, are similar to them.

When television grows to commercial manhood, it will merely advance from the by-product stage to full-fledged partnership with the radio industry. From the standpoint of this combined radio and television industry with its many amusement ramifications, the industrial uses are obviously destined to fall into the classification of allied industries not logically adapted to direct association. But in the pioneer stages, these

TELEVISION APPLIANCES

by-products of television may be the avenue to commercial and economic growth. The development work undertaken to maintain a position in these associated fields will, no doubt, lead to many improvements which may be embodied in television equipment.

Sound Motion Pictures as a Field for Television Manufacturers.

Television owes the availability of practical commercial photoelectric cells largely to research and development work undertaken for talking pictures and facsimile systems. Talking motion-picture recording on film involves a system somewhat paralleling the functioning of a television scanning apparatus. Sound waves are impressed on a microphone associated with a vacuum-tube amplifier system, the output of which controls a light source directed upon a narrow section of the film known as the sound track. One system of recording known as the variable-density method employs a variable aperture magnetically controlled by the audio currents originating with the microphone, which increases or decreases the intensity of the light projected on the film. Another method of securing the variable light required for recording with the variable-density method is closely similar to that employed for securing a variable light for television reproduction. The amplified sound currents are fed to a glow lamp, corresponding to the familiar neon tube, known as an Aeo lamp. It depends upon a luminous charge taking place in actinic gas for its response to fluctuations in applied voltage. Another type of sound recording on film uses a vibrating mirror like that of an oscillograph, which makes a relatively

TELEVISION

wide band of light on the sound track in response to a sound impulse of maximum intensity and a narrower band for smaller intensities. This is known as the variable-area system.

The range of frequencies employed in sound is narrow as compared to that required by television. The problem in connection with talking motion pictures is not so much to extend the range of response as it is to develop rugged equipment responding faithfully to the required range. The range of frequency handled by the reproducer on the stage loudspeaker limits the useful recorded range to perhaps eight thousand cycles. Consequently, it has been possible to concentrate development work on improved fidelity and reliability without considering increased range, the primary problem of the television engineer. In working along these lines, contributions have naturally been made toward reliable television apparatus.

The heart of the equipment used for the reproduction of talking motion pictures is the photoelectric cell. Regardless of the method used in recording on film, the reproduction process is similar. A fixed light source is projected through the sound track on the film and a variable light produced, fluctuating to correspond to the original speech and music recorded. The light is focused on a photoelectric cell so that its current output is a counterpart of the originating sound waves. The current produced is amplified by vacuum tube to the point where sufficient power is available to actuate the bank of loudspeakers behind the screen.

The quantity requirements for photoelectric tubes for use in the motion-picture theaters are fairly con-

TELEVISION APPLIANCES

siderable. While it is quite probable that eventually photoelectric tubes of much higher quality than is required for sound production will be developed for television purposes, the fact there is a market already existing for photoelectric tubes can be useful in stabilizing production and justifying research expense in tubes especially adapted to television.

Facsimile Telegraph Equipment as a By-product of Television.

Facsimile telegraphy, phototelegraphy or transmission of photographs over wire lines in a similar way involves the technique of the television engineer. Fundamentally, a facsimile is television without the maintenance of the elements of motion. Facsimile has the same relation to television that the stereopticon has to motion pictures.

Research in phototelegraphy followed closely upon the invention of the telegraph itself. Numerous methods have been devised depending upon mechanical contactors working from the face of a copper etching. The more modern systems closely parallel the methods of television.

While there are numerous methods and systems, the same fundamental principles apply to most modern facsimile devices. A negative transparency of the photograph to be transmitted is mounted on a glass cylinder on a fine spiral thread. A fixed pencil of light is projected through the cylinder which, because of its spiral motion, progressively explores the entire transparency. The light passing through the negative controls the output of the photoelectric cell producing the picture signal.

TELEVISION

This process is closely analogous to a television system except that we have the field of view in the exceedingly convenient form of a photographic negative and that we are faced with no time limitation to complete scanning. We do not depend upon light reflected for varying distances as with television, because the field of view is first conveniently reduced to a single layer of varying density by photographic process.

Since we may take as long as we please to complete a single scanning of the field of view, the picture signal may embody a vast number of picture elements. A 4 by 5 photograph may be readily broken down into over 100,000 picture elements, yet only a narrow communication channel is required for its transmission. One to three minutes can be used in the process of transmitting the picture signal representative of 100,000 picture elements instead of $\frac{1}{20}$ second as with television, because, in the former case, the collation of these elements is accomplished in permanent form by photography, and in the latter it must be accomplished by the eye itself.

Reproduction of Facsimile Pictures.

Reproduction of the still picture at the distant point involves a magnetically controlled light valve which controls the intensity of a fixed light ray, directed to a cylinder of the same proportions and rotating in the same manner as the one upon which the transparency is mounted for transmission purposes. Mounted on this cylinder is photographic paper which is exposed by the fluctuating light source.

TELEVISION APPLIANCES

After progressive exposure, the photograph is finished in the usual way.

Many elements of the television system are employed in the typical facsimile process. The subject is scanned by a photoelectric cell and the resulting picture signal converted into corresponding light. Transmitting and receiving motors are maintained in accurate synchrony. The elimination of the limitation that scanning must be completed within a fixed period, such as a twentieth of a second, makes possible facsimile reproductions of practically perfect texture that can be sent over telephone wires of no broader range than are used for broadcast pick-up work. Such photographs are used interchangeably with original photographs in newspaper work without any discernible sacrifice of clarity.

Special Features of Various Systems.

Pictures sent across the Atlantic by radio are not of such good quality because of long distance transmission through the unstable radio medium. In fact, until Captain R. H. Ranger invented and developed an ingenious system in which the light intensities traced on the reproduction are controlled not by signal intensity but by signal duration, the effects of fading and other disturbances made long distance transmission of pictures of commercial quality impossible.

There are also other variations from the typical facsimile transmission system first described. In transmission, for example, a positive print may be used on a cylindrical drum. The light is then reflected from the photograph to the photoelectric cell instead of being projected through it. This method intro-

duces problems of spectral diffusion, but it is one of great practical convenience. At the reproducing end, likewise, various methods may be used to trace the reproduction on the desired surface. One system developed by Austin G. Cooley employs the brilliant corona discharge for exposing the photographic paper. Corona is rich in ultra-violet rays and the frequency of the light produced is at the end of the spectrum to which photographic paper is the most responsive. Consequently, papers of slow exposure can be used, which is not the case when feebler sources of illumination are employed. Therefore, elaborate precautions, such as operating the reproducing equipment only in feeble red light, necessary with systems in commercial use, are obviated. In fact corona reproduction has developed to the point where it can be carried out in broad daylight.

Light-sensitive Devices for Industrial Control.

Another class of device of great commercial promise is the application of light-sensitive devices to industrial control. Light source, photoelectric cell amplifier and control relay constitute a combination having a seemingly endless number of applications in industry. Devices of this character may be divided into two classes, first, those depending upon interception or mere presence or absence of light, and, second, those which are controlled by accurate response to varying light intensity. The interception classification includes such devices as burglar alarms, sound devices, safety and warning units. A light beam may be directed to the combination of a safe. If any person or object intercepts that beam of light, a photoelectric

TELEVISION APPLIANCES

cell with associated amplifier immediately closes a relay which may be used to control any electrical operation. The light ray to be intercepted may be of infra-red, which is invisible. A similar system may count containers passing on a moving belt, to start off machinery when material for fabrication appears, or may actuate a warning device when a person or object steps into the ray of light marking the limits of safety.

Photoelectric devices of the second class may be designed to respond to total reflection or only to reflection of one color or frequency. Total reflection is involved in photometers, smoke recorders and paper-grading machines. Devices measuring intensity for each frequency of the visual spectrum are called spectrophotometers. Color measuring by photoelectric analysis is involved in applications such as cigar sorters, bean sorters, coffee-roasting controllers, dye measuring indicators and automatic color recorders.

The reason why such devices are likely to have extensive employment in industry is that they are far more rapid and accurate in response than the human eye. A trained operator may be able to sort two or three objects of a certain kind per second, but a photoelectric device can sort hundreds. In fact, the limit is in the mechanical systems to handle the product and not in the light-sensitive system. Unlike the human operator, moreover, the photoelectric device is not subject to fluctuations due to fatigue or changing conditions of illumination.

While these applications are not so closely related to television as it might appear, both the engineer and production facilities necessary to produce them are

TELEVISION

similar to those needed in television manufacture. It is obvious, therefore, that the television industry has in

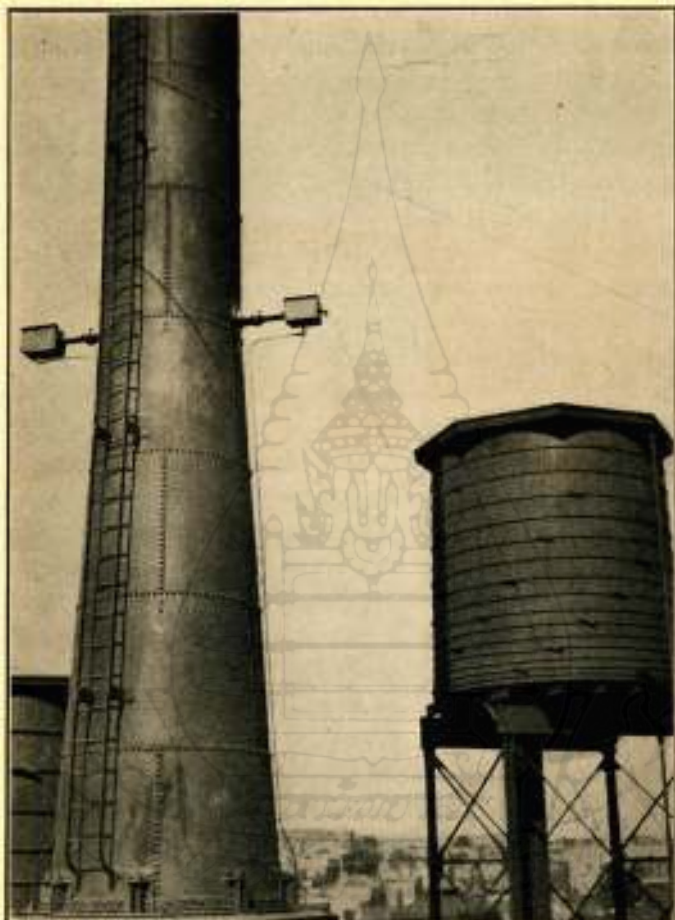

FIG. 72.—A photoelectric smoke-density recording and warning device.
(Courtesy of Westinghouse E. & M. Co.)

the manufacture of parts for talking motion picture, facsimile and industrial control devices, a means of

TELEVISION APPLIANCES

attaining production stability and freedom from excessive seasonal characteristics. The radio-receiver business has found this the pitfall that has wrecked many of its pioneers who once enjoyed prosperity.

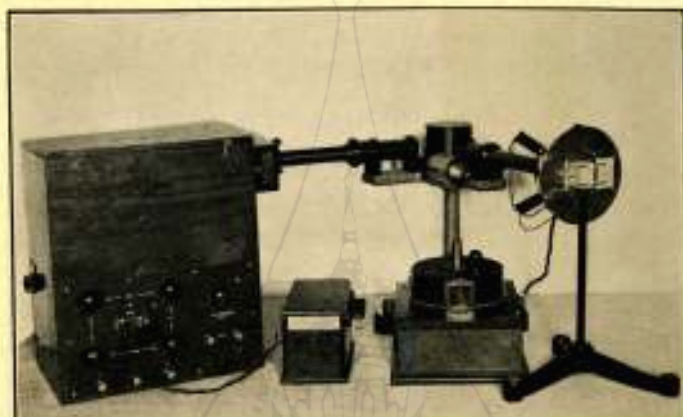

FIG. 73.—A photoelectric spectrophotometer developed by the American Photoelectric Company for accurate color analysis throughout the visible spectrum.

With the example of the radio industry before us, it is possible for producers of television apparatus to avoid the economic suicide involved in the concentration of facilities in production which is pushed only during a small part of the year and which cannot be carried over successfully from season to season.

CHAPTER XVII

THE FUTURE PROGRESS OF TELEVISION

The progress of every widely used invention from original conception to commercial acceptance has been slow and wearying. Only the pioneers remember the struggles against technical obstacles, financial discouragement and public inertia, which have characterized the early history of every major innovation. The motion picture, the automobile, the airplane and radio telephony, each struggled ten to fifteen years between the first practical demonstration and general acceptance.

Public Demands Perfected Television.

From the technical standpoint, the road which television must travel is rendered doubly difficult because the public has already set high standards of performance which must be met before general acceptance can be expected. The motion picture, on the one hand, has developed a definite conception of the attainable quality of visual reproduction, and sound broadcasting, on the other, has demonstrated how successfully a radio-communication system can convey all the information requirements of the sense of hearing. By simple but fallacious logic, acceptable television is, to the general public, the delivery of images of motion-picture quality into the home by radio. Anything

THE FUTURE PROGRESS OF TELEVISION

less than that standard is considered merely as an experiment. Apparently television faces a tremendous handicap which, to be overcome, implies the successful solution of every major technical problem which today marks the boundaries of progress in the art.

Once sufficient technical and program progress has been made, however, the attainment of public recognition and acceptance will be easier in the case of television than for any previous invention of as broad a scope. Television is eagerly awaited. The commercial structure to carry out the essential broadcasting services is fully organized and operating under the direction of experienced executives. The facilities and personnel for the manufacture and distribution of reproducers for the home user are likewise fully established. Indeed, the acceptance for television is so highly developed that failure to deliver a product of commercial standards in the relatively near future will actually tend to weaken public confidence and will make more difficult the introduction of television when it is finally ready to make its bow as a regular program service.

Broadcasting's Long Struggle from Conception to Acceptance.

The short memory of the public in respect to the struggles of the pioneer is no better illustrated than by the history of sound broadcasting. The date considered the most important landmark in the progress of broadcasting is November 2, 1920, when KDKA broadcast the Harding election returns. In an amazingly short space of years from that date, a nationwide

TELEVISION

broadcasting system was established, a manufacturing industry organized, and a national retail distribution structure reaching to every hamlet evolved.

But the only thing that makes November 2, 1920, significant in radio broadcasting is that it happens to be the particular incident that caught the public fancy and marked the beginnings of public acceptance. KDKA is no more the first broadcasting station than was the first automobile equipped with a self-starter the first automobile. There were literally scores of broadcasting stations preceding KDKA, some offering spasmodic and others maintaining regular service. Indeed, even Enrico Caruso can be numbered as a broadcast artist, his voice having been broadcast by Dr. Lee DeForest in 1909 through his radio telephone station. Stock promotion of radio telephone companies flourished in 1906. R. A. Fessenden demonstrated radio-telephone communication for a distance of 16 miles from Brant Rock to Plymouth, Mass., on December 11 of the same year. A few months later voices and music were heard from Brant Rock at Jamaica, Long Island, a distance of 180 miles. The period from 1906 to 1920 was an intensive struggle to overcome major technical problems in radio telephone.

The first important demonstration of television was staged by C. Francis Jenkins in Washington, D. C., on June 13, 1925, before Secretary of the Navy Wilbur, Dr. George M. Burgess, director of the Bureau of Standards, and other notables. The transmitter was installed at Naval Radio Station NOF at Bellevue, D. C., and the reproduction apparatus at the Jenkins laboratory in Connecticut Avenue. The subject of the transmission was a strip of motion-picture film.

THE FUTURE PROGRESS OF TELEVISION

Since that demonstration, progress in the art has been steady and the research effort expended unstinting. Television is entitled to a fair quota of time for development in the laboratory and, in the light of experience with previous inventions of similar magnitude, it has not lagged unduly.

Electronic Control of Reproduction Light Essential.

Many engineers who have worked intensively with television are frank to admit that there are stumbling blocks to progress which cannot be scaled but which must be circumvented. The two hurdles of the most imposing character to be overcome are the discovery of a practical non-mechanical scanning means and of a method of sidestepping the apparent channel limitations. I am very doubtful that high-quality television will ever be accomplished by a mechanical method of distributing a fluctuating ray of light on the field of reproduction. It is essential that we control the direction and intensity of the light source by electrostatic or electromagnetic fields having the facility of acting as rapidly as light itself. The Karolus cell, which has been described,¹ is one such means of controlling the intensity of a light beam by effecting minute changes in the phase of doubly refracted polarized rays. The cathode-ray tube accomplishes a control over both direction and intensity of the light beam non-mechanically. In one of these, or in some similar method, lies the solution of the problem of the distribution of light in the reproduction.

The fact that the cathode-ray tube, as we know it today, has a life of but a few hours should be no cause

¹ See pages 116-124.

TELEVISION

for discouragement. Dr. Alexander Meissner demonstrated radio telephony between Berlin and Nauen, a distance of 23 miles, in June, 1913. Contemporary engineers pointed out the futility of this experiment because the vacuum tubes used under the conditions lasted only 10 minutes on account of disintegration of the filament by positive ionic bombardment. The probabilities are that we already have with us today the beginnings of the device which will come to the forefront as the means of making high-quality home reproduction possible but, because of apparently serious deficiencies, it is regarded as unpromising.

Channel Limitations Imposed by Progressive and Continuous Scanning.

The widest band of modulation which has ever been used for television is from 10 to 36,000 cycles. This is the band width required for transmitting 60-line images at the rate of 20 repetitions per second. Bell Laboratories engineers used from 10 to 40,000 cycles for the 72-line wire television in 1930. With progressive scanning involving an impulse for every picture element in the reproduction within the time that the eye can collate these elements as a continuous image, 100-kilocycle channels seem likely to prove inadequate. But the capacity of 100-kilocycle channels has never been tested, nor will we know exactly what entertainment value can be offered through them until we have seen 100-kilocycle television in practice.

The remarks of Dr. Frank B. Jewett, president of the Bell Telephone Laboratories, at the public demonstration of television reproduction at New York with

THE FUTURE PROGRESS OF TELEVISION

subjects in Washington, are significant and have lost none of their force and applicability:

While research and development work for the perfection of television will go on for years, enough has already been accomplished to indicate that it is likely to have a real place in the world's work of distant communication. Today (1927) we are relatively farther along in our work on television than we were on transoceanic telephony in 1915 when the American Telephone and Telegraph Company conducted the first successful test from Washington to Paris and Honolulu. Just what the ultimate field of television is to be can, as Mr. Gifford has said, be left to your imagination. The one thing that seems clear is that it will be a use closely associated with the telephone.

In attempting to form a picture as to the future development of television, there is one inherent limitation of any television method which we should keep clearly in mind, however. This is the fact that it requires the use of a large group of frequencies and the transmission of these frequencies requires as great capacity as a considerable number of ordinary telephone circuits. It is this fact which puts television economically into a class quite different from that of ordinary telephony or telegraphy.¹

Improved Brilliance and Contrast Reduces Channel Requirements.

We are still far from leaping the channel limit hurdle, although practice may prove somewhat more generous than theory in respect to the image embodied in a signal using the whole available channel. After all, the calculations made for picture-element requirements are based on the assumption that the resolving power

¹ JEWETT, DR. FRANK B., *Bell Laboratories Record*, Vol. IV, No. 3, May, 1927.

of the eye is of a definite value. The value, however, as I have pointed out, is altered by the brilliance of the image viewed and its contrast. The values chosen for the calculations are based on the brilliance and contrast available for home motion-picture reproduction. If a method is developed for securing greater brilliance and contrast in television reproduction, the picture element requirements for a given clarity are reduced. The calculations made are justified only by the fact that there is no method in sight of projecting a more powerful image than we secure in the motion-picture field.

But there is no valid reason for believing that the science of television, realizing its necessity, will not develop a controlled light source of greater intensity. Therefore, to assume that the 100-kilocycle limitation erects a definite barrier to the amount of detail in a television image is not justified because, first, we have never tested the capacity of 100-kilocycle channels and, second, we have undertaken no development work looking toward the employment of greater brilliance and contrast than is used in motion-picture work.

Circumventing the Channel Limitation.

The most fundamental assumption which is made in defining the limitations of television is that a communication impulse must be transmitted for each picture element at least 20 times a second. But there are no grounds for such an assumption. Suppose, for example, that someone developed an effective phosphorescent screen such that an impulse of 1/1,000 second set up illumination lasting a full second.

THE FUTURE PROGRESS OF TELEVISION

Suppose further that there is no motion in the field of view. In that case, to maintain that scene before the eye, it would have to be scanned only once a second instead of 20 times a second. Obviously, the scene could consist of 200,000 picture elements and still be transmitted within the limitations of 100-kilocycle channels.

Another expedient to escape the channel limitation would be the use of photography instead of the eye for collation of the image. Supposing the television reproducer directs a ray of light onto a strip of unexposed motion-picture film. If the scanning process is conducted at the rate of one frame per second, it would take 20 times as long to make the film as to reproduce it through a home projector. But it would be possible to offer a news-reel service of the air for reproduction by the standard 16-millimeter reproducer. The television reproducer would be tuned to the station sending the news reel, comedy or drama and allowed to operate automatically making film. The device might also have automatic means of finishing the negative. Although it would require an hour to make an amount of news reel which is exposed in 5 minutes, this fact would be of no special annoyance to the observer, since the operation of making up film is presumed to be automatic.

There are obvious practical mechanical difficulties which stand in the way of rendering a general service by the method described. The main point is merely to show that there are conceivable methods of circumventing the channel limitation. The limitations are not in the channels; they are imposed by the methods employed in the scanning and reproducing systems and

TELEVISION

the religious adherence to a relatively ancient conception of television scanning.

Fresh Viewpoint Needed to Produce Improved Television.

The most important needs to produce a practical television service are minds and imaginations which approach its technical problems with a fresh point of view, and which do not merely accept the orthodox method already exhaustively investigated by numerous inventors. The problems of television are not insuperable, nor are they more difficult than those which faced the inventors of any generally accepted entertainment of communication device. Their solution will have the inherent simplicity characteristic of every practical invention. We are familiar with so many elements of the ultimate television system that it is no strain to prognostic powers to predict that television is "just around the corner." The probabilities are, however, that most of us are congregated hopefully on the wrong corner.

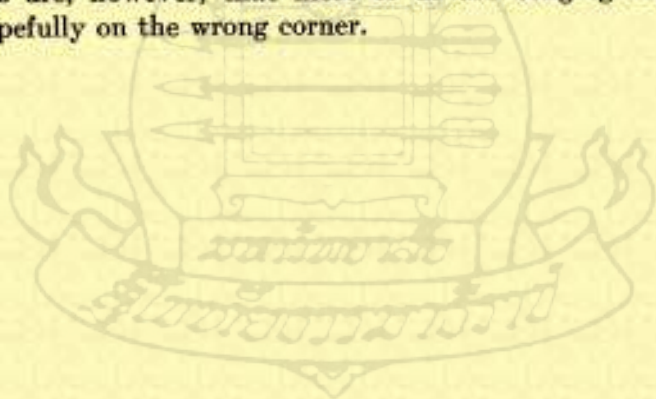

INDEX

A

- Advertising by television, 222-232
effectiveness, 231-232
programs, 222-227
technique, 228-232
testimonial, 226-231
- Alexanderson, Dr. E. F. W., analysis of projection, 134
Karolus projector, 120-124
observations on echo effects, 88-89
- Appliances, television, industrial and commercial applications, 247-257
- Audience, television, experimental element, 235-236
performance standards necessary to establish, 26-27, 234-236

B

- Band selector, 96-98
- Bell System, color television, 107, 135-136
50-line television, neon grid screen, 110-112
picture signal, maximum frequency of, 77
progressive illumination scanning, 38-39
superheterodyne receiver, 98-99
synchronizing, 153-155

- Bell System, 72-line television, neon water-cooled tube, 104-106
progressive illumination scanning, 39-41
synchronizing, 155-157
transformer coupled amplifier, 101
neon glow tube, concentrated ray, 106, 120
selective fading investigation, 85-87
- Broadcast receivers, usefulness in television reception, 74-75, 92-95
- Broadcasting and television, early histories compared, 259-261

C

- Cathode ray tube, 112-115
- Channel requirements, methods of reducing, 262-266
tabulations for detail and repetition rates, 199-200
(See also Picture signal.)
- Channels, transmission, assigned to experimental television, 94
discriminating between neighboring, 92-93
- Color, elimination of, effect on reproduction, 15-14
- Color response, eye, 167-168
photoelectric tubes, 62-66
- Color television, Bell System demonstration of, 107, 135-136

TELEVISION

Commercial possibilities of television (*see* advertising, television, performance standards).
 Cooley, A. G., facsimile system, 254
 Communication, nature of, 7
 Crystal oscillators for synchronization, 158-159
 Cuprous oxide cell, 59

D

Detail, brain, information requirements of, 181-184
 channel requirements imposed by, 83, 199-200
 definition of, 181
 distortion to, introduced by coarse scanning, 36-38
 by inadequate transmission system, 83-84
 eye requirements for, 183-191
 factors determining requirements, 184
 half-tone screen, values of, 14-18
 picture signal frequencies, higher, contribution to, 78-79
 requirements in television reproduction, 179-205
 selective fading, effect on reproduction of, 87-88
 square aperture disc, effect on, 36
 uniform, necessity for, in entire scene, 174-175
 (*See also* Picture signal.)
 Developments in television, nature of recent, 2
 Disc scanning (*see* Scanning disc).

E

Economic structure for support of television, 224-226
 Educational uses for television, 212-215

Enlargement of reproduced image, 134-135, 189-190
 Entertainment service, experimental television, program possibilities of, 239-240
 prospects for development of, 233-246
 requirements to secure public acceptance, 26-27, 203-205, 234-235, 258-259
 time required to develop, compared with broadcasting, 259-261
 Entertainment value, analysis of, 201-205
 early broadcasting compared with television, 236-237
 48- and 60-line television, 210-215
 100-line television, 215-219
 Eye, adjustments of, 165-166
 for television reproduction, 166-167
 to darkness, 169
 color response of, 167-168
 field of view of, 166
 exploration of, 173-174
 information to, motion picture and television compared, 52-55
 interfering illumination, effect on, 171-172
 persistence of vision, 170-179
 resolving power of, 185
 response to motion, 175-176
 to shading, 170-171
 sensitivity, 169-170

F

Facsimile telegraphy, 251-254
 Facsimile transmission, definition of, 6
 Field of view, definition of, 6

INDEX

- Field of view, reconstruction, 24-25
- Framing, definition of, 139
 means for accomplishing, 161-162
 synchronization, distinction between, 139-140
- Fundamental processes of television, 26
- Fundamental television system, description of, 27-29
- G
- General Electric Company, 88-89, 120
- H
- "Hunting" in synchronization system, 151
- J
- Jenkins, C. Francis, drum scanner, 108-109
 projector, 135
 television system receivers, 99
- K
- Karolus projector, 120-124
- Kerr Principle, 116-117
 (See also Karolus projector.)
- L
- Light-sensitive element, 56-72
 definition, 56
 requirements in television, 57
 (See also Photoelectric cell.)
- Light source for television reproduction (see Cathode ray tube; Neon glow tube; Karolus projector).
- Light valve and variable light source, distinction between, 115-116
- Lines, definition of, 30
- M
- Motion picture, picture elements in, 192-193
 film, scanning of, 50-52
- Motion pictures and television, comparison of, 52-55
- N
- National Broadcasting Company, 86, 89-90
- Neon glow tube, 102-112
 concentrated ray for projection, 106, 129
 Jenkins multi-element, 109
- Neon grid screen, 110-112
- Nicol prisms, 119
- P
- Performance standards, means of evaluation of, 12-13, 49-50
 necessary to public acceptance, 26-27, 234-235
- Persistence of vision, 25, 132, 176-179
- Photoelectric phenomenon, 56-59
- Photoelectric tube, characteristics of, 62-68
 color response, 62-66
 coupling to amplifier, 69-72
 description of, 59-61
 gas type, 61-62
 industrial applications, 254-257
 principle of, 59
 sensitivity of, 66-68
 television service requirements of, 71-72
 Wein cell, 59
- Phototelegraphy, definition of, 6
- Picture elements, brilliance, relation to number required, 131
 definition of, 30
 increase of, for enlarged reproduction, 190-192

TELEVISION

Picture elements, motion pictures,
192

number for scene of perfect
texture, 186-189, 194

Picture signal, channel require-
ments, analysis of, 81-83

calculation of, 75

table of, 199-200

converting to light, 102-125

definition of, 23

higher frequencies, contribution
to detail, 78-79

information embodied in, 102

low frequency requirements, 80

maximum frequency in, 76-78

synchronization, relation to, 137

transmission of, 73, 91

Picture transmission, definition of,
6

Polarized light, 117-119

Predictions, practical television
service, 2-4, 147, 263

Programs, television, and broad-
casting, 223-228

motion picture quality stand-
ards, 219-221

possibilities of, 206-221

for variable repetition and
detail, 216-219

sporting events, 242-243

technical limitations, 206-208,
213-214

Projection, advantages gained by,
172-173, 198

concentrated neon glow tube,
106, 129-130

development, prospective, 133-
134

Karolus method, 120-124

Publicity, television, 238

Q

Quality, definition of, 181

R

Radio-frequency amplifier, tele-
vision receivers, 95-101

Random voltages in coupling re-
sistors, 34-35

Ranger, Capt. R. H., facsimile
system, 253-254

Raytheon glow tube, 103-104

Receivers, broadcast, for television,
74-75, 92-95

radio-frequency amplifiers of,
95-101

requirements for television, 92-96

superheterodyne, 98-99

television design, 243-244

Reception of television signals,
92-101

Repetition rate, definition of, 19
minimum, 127-128

varying, possibilities of, 196-197,
217-219

Reproduction, brilliance, relation
to detail, 177-179

enlargement of, 134-135, 189-192

entertainment value, analysis of,
201-205

faithful, 137-139

forming image in, 126-136

future development of, 261-263

ideal subject for, 79-80

illumination, effect on response,
168-172

selective fading, effect of, 87-88

Resistance-coupled amplifiers, 69-
72, 99-101

S

Scanning, definition of, 21

Jenkins' drum, 108

motion picture film, 50-52

necessity for, 31

INDEX

- Scanning, progressive illumination,
 advantages of, 41-43
 description of, 32-33
 progressive observation, de-
 scription of, 32-34
 and progressive illumination of
 compared, 32
 purpose of, 30
 rating, method for, 49-50
- Scanning disc, development of,
 47-48
 effect of large apertures, 35
 lens scanning type, 46
 limitations of, 44, 128-129
 moving mirrors for, 46
 prismatic, 45
 staggered spiral type, 47
- Selective fading, 85-88
 description of, 85
 effect on television reproduc-
 tion, 87-88
 methods of overcoming, 86-87
- Selectivity, band selector, 96-98
 requirements for television recep-
 tion, 92-96
- Selenium, 57
- Shading, eye response to, 170-171
- Short-wave synchronization signal,
 157-158
- Sound accompaniment for tele-
 vision, 94-95, 208-216
- Sound communication, compared
 with visual, 7-11
- Sound motion pictures, 249-251
- Standardization, television, 243-246
- Synchronization, 137-160
 accuracy required, 141-142
 Bell System, 50-line demonstra-
 tion method used in, 153-155
 72-line demonstration method
 used in, 155-157
 clutch method, 143
 definition of, 24, 139
- Synchronization, early attempts,
 142-148
 effect of inaccurate, 140-141
 framing, distinction between,
 139-140
 independent crystal oscillator for,
 158-159
 manual, 144-148
 photoelectric tube, use in, 150-
 151
 power line, 148-150
 short-wave signal, 157-158
 tuning-fork method, 160-161
- ### T
- Technical developments, future
 direction of, 261-266
- Television, broadcasting as supplе-
 ment to, 208-216
 definition of, 5
 fundamental processes of, 26
 typical system, 27-29
- Transmission channel, calculation
 of requirements, 75-76
 capacity of 100 kilocycle chan-
 nels, 76
- Transmission, television, channels
 assigned to, 94
 echo effect, 88-91
 radio necessary to conclusive
 demonstration, 84
 reflections in, 88-91
 requirements, channel, 75-84
 (See also Picture signal; Selec-
 tive fading.)
- ### V
- Visual communication, nature of,
 10
- ### W
- Wave length of radiations, table, 60
 Wein cell, 59

TELEVISION

Wire television, definition of, 5-6
significance of demonstration of,
84

Wired radio, prospective use for,
90

Z

Zworykin, Dr. Y. K., cathode-ray
tube developed by, 114-115
tuning-fork synchronizing sys-
tem, 160-161



